

STRUCTURAL DRAWING INDEX

PROPOSED NEW RELOCATABLE HOMES

CLIENT : HEARN
SITE : LOT 2 DP1014531
 87 HENRY BAYLY DRIVE
 MUDGEES NSW 2850
BUILDER : HI-TECH HOMES PTY LTD

DRAWING INDEX

DRAWING NUMBER	DRAWING CONTENT
S01	GENERAL NOTES 1
S02	GENERAL NOTES 2
S03	TYPICAL BUILDING CROSS SECTION
S04	PAD FOOTING AND ANCHOR LAYOUT
S05	TYPICAL FOOTING & ANCHOR DETAILS
S06	TYPICAL FLOOR FRAME LAYOUTS
S07	TYPICAL WALL FRAME DETAILS
S08	TYPICAL ROOF FRAME DETAILS

AUSTRALIAN STANDARDS

THE DESIGN IN ACCORDANCE WITH THE FOLLOWING AUSTRALIAN CODES & STANDARDS	
AS1170.1-2002	STRUCTURAL DESIGN ACTIONS - PART 1: PERMANENT, IMPOSED AND OTHER ACTIONS.
AS1170.2-2011	STRUCTURAL DESIGN ACTIONS- PART 2: WIND ACTIONS
AS 4055-2012	WIND LOADS FOR HOUSING
AS1170.3-2003	STRUCTURAL DESIGN ACTIONS - PART 3: SNOW AND ICE LOADS
AS1684.2 - 2010	RESIDENTIAL TIMBER FRAMED CONSTRUCTION.
AS1720.1- 2010	TIMBER STRUCTURES
AS 2870-2011	RESIDENTIAL SLABS AND FOOTINGS
AS 3600-2018	CONCRETE STRUCTURES
AS 4100 -2020	STEEL STRUCTURES
AS 4600- 2018	COLD-FORMED STEEL STRUCTURES

ISSUED FOR APPROVAL



Halina Engineers Pty Ltd
 w: halina.com.au
 e: harry@halina.com.au
 t: 0402.296.323

rev.	date	Amendment
A	22/01/2024	ISSUED FOR APPROVAL

Client HEARN
 Project LOT 2 DP1014531
 87 HENRY BAYLY DRIVE
 MUDGEES NSW 2850

Drawing title FRONT PAGE
 Original size A3

Job number	4829	Approved by	
sheet	S00	rev.	A
design		draft	

HA NGUYEN
 BE(HONS) PHD CPEng NER

GENERAL NOTES

- CONSTRUCTION FROM THESE DRAWINGS SHALL NOT COMMENCE UNTIL THEY ARE APPROVED BY THE RELEVANT AUTHORITIES.
- THESE DRAWINGS AND NOTES SHALL BE READ IN CONJUNCTION WITH ALL ARCHITECTURAL AND OTHER CONSULTANTS DRAWINGS, REPORTS, SPECIFICATION AND WITH SUCH OTHER WRITTEN INSTRUCTIONS AS MAY BE ISSUED DURING THE COURSE OF THE CONSTRUCTION. ALL DISCREPANCIES SHALL BE REFERRED TO THE ARCHITECT FOR DECISION BEFORE PROCEEDING WITH THE WORK.
- DIMENSIONS SHALL NOT BE OBTAINED FROM THE STRUCTURAL DRAWINGS BY WAY OF SCALING THE STRUCTURAL DRAWINGS. WALL, PIER, AND COLUMN THICKNESS AND STRUCTURAL MEMBER SIZES SHOWN ON THESE DRAWINGS SHALL TAKE PRECEDENCE OVER THESE SHOWN ON THE ARCHITECT'S DRAWINGS. THE BUILDER SHALL VERIFY ALL DIMENSIONS ON SITE AND BE RESPONSIBLE FOR THE SETTING OUT OF THE BUILDING
- ANY DISCREPANCIES/ SUBSTITUTION IN THESE DOCUMENTS SHALL BE REFERRED TO THE ENGINEER FOR DECISION BEFORE PROCEEDING.
- STRUCTURAL ENGINEERING DRAWINGS ARE ISSUED ON THE UNDERSTANDING THAT THE BUILDER MAINTAINS IN FORCE, PROPER AND ADEQUATE CONTRACT WORKS INSURANCE AND PUBLIC LIABILITY INSURANCE DURING THE FULL COURSE OF THE CONSTRUCTION, AND/OR ANY MAINTENANCE PERIOD. CLAIMS OF DAMAGE TO ANY ADJACENT PROPERTY OF BUILDING IS NOT THE RESPONSIBILITY OF THE ENGINEER.
- ELEMENTS INDICATED ON THESE DRAWINGS ARE SHOWN IN THEIR INTENDED COMPLETE STATE. DURING CONSTRUCTION, THE BUILDING SHALL BE MAINTAINED IN A STABLE CONDITION AND NO PART SHALL BE OVERSTRESSED AT ANY TIME. TEMPORARY WORKS INCLUDING BRACING, PROPPING AND ANY OTHER REQUIREMENTS SHALL BE PROVIDED BY THE BUILDER AS REQUIRED. THE BUILDER SHALL BE RESPONSIBLE FOR ANY DAMAGE TO THE WORKS DURING CONSTRUCTION.
- ALL WORKMANSHIP AND MATERIALS SHALL BE IN ACCORDANCE WITH THE REQUIREMENTS OF THE CURRENT EDITIONS OF THE BCA AND THERE-BY LAWS AND ORDINANCES OF THE RELEVANT BUILDING AUTHORITY.
- THE SECTIONS/ DETAILS ON THESE DRAWINGS ARE INTENDED TO GIVE THE STRUCTURAL SPECIFICATIONS ONLY.
- THESE DOCUMENT ARE SIGNED SUBJECT TO CERTIFICATE OF INSPECTION BEING ISSUED BY HALINA CONSULTING. ALL PIERS, SLAB AND FOOTING REINFORCEMENT SHALL BE INSPECTED BY THE ENGINEER PRIOR TO THE POURING OF CONCRETE. NOTICE SHALL BE GIVEN AT LEAST 24 HOURS BEFORE ALL THE REQUIRED INSPECTION.

SITE CLEARANCE & PREPARATION

- ALL TOPSOIL, ORGANIC AND DELETERIOUS MATERIAL IS TO BE STRIPPED FROM THE BUILDING SITE.
- ANY FILL USED IN THE CONSTRUCTION OF A SLAB EXCEPT WHERE THE SLAB IS SUSPENDED SHALL CONSIST OF "ROLLED OR CONTROLLED FILL". FILL MATERIAL SHALL BE PLACED IN LAYERS OF 150mm MAXIMUM IN ACCORDANCE WITH AS2870 AND THOROUGHLY COMPACTED USING AN EXCAVATOR. UNLESS THIS FILL IS COMPACTED IN ACCORDANCE WITH AS2870, IT IS NOT ADEQUATE FOR THE LONG TERM STRUCTURAL SUPPORT TO THE SLAB/ FOOTING SYSTEM AND PIERS MUST BE CONSTRUCTED.
- TO BE ADEQUATE TO SUPPORT THE SLAB/FOOTING SYSTEM, CONTROLLED FILL SHALL BE PLACED, TESTED AND CERTIFIED BY A QUALIFIED GEOTECHNICAL ENGINEER AS DEFINED IN AS3798.
- THE FILL IS TO EXTEND PAST THE EDGE OF THE SLAB BY AT LEAST ONE METRE AND SHALL BE BATTERED OFF NOT STEEPER THAN TWO (HORIZONTAL) TO ONE (VERTICAL) OR BY A SUITABLE RETAINING STRUCTURE PROVIDED BY THE OWNER OF BUILDER.
- THE FINISHED LEVELS SHALL ALLOW FOR THE MAIN SLAB TO BE AT LEAST 150mm ABOVE THE ADJACENT GROUND.
- SURFACE DRAINAGE SHALL BE PROVIDED AS REQUIRED TO AVOID THE POSSIBILITY OF WATER PONDING NEAR THE SLAB. A FALL OF 50mm OVER A DISTANCE OF ONE METRE AWAY FROM THE SLAB IS CONSIDERED ADEQUATE. SUBSOIL DRAINS (AGRICULTURAL DRAINS) ARE CONSIDERED DESIRABLE BUT SHOULD BE AVOIDED BEING LOCATED DIRECTLY ADJACENT TO THE FOOTING.
- ANY TREES LOCATED WITHIN $\frac{1}{3}$ OF THEIR MATURE HEIGHT OF THE HOUSE ARE TO BE REMOVED AND BACKFILL WITH THE SUITABLE MATERIAL INTO THE SOFT SPOTS. COMPACT THE BACKFILL SOIL AS INDICATED ABOVE.

REINFORCE CONCRETE NOTES

- ALL WORKMANSHIP AND MATERIALS SHALL BE IN ACCORDANCE WITH AS3600 AND AS2870.
- UNLESS NOTED OTHERWISE, QUALITY OF CONCRETE SHALL BE USED AS FOLLOW:

ELEMENT	SLUMP	MAX. AGG. SIZE (mm)	CEMENT TYPE	CONC. GRADE	EXPOSURE CLASSIFICATION
PIERS	80	20	A	N20	A1
FOOTING & SLAB ON GROUND	80	20	A	N25	A1
SUSPENDED SLAB	80	20	A	N32	A1

- UNLESS NOTED OTHERWISE, COVER FOR REINFORCEMENT SHALL BE PROVIDED AS FOLLOW:

ELEMENT	CAST AGAINST FORMS		CAST AGAINST GROUND	
	INTERIOR	EXTERIOR	PROTECTED	UNPROTECTED
PIERS	40	40	50	40
FOOTINGS	50	50	50	50
SLABS	20	40	30	40
WALLS	40	40	50	50
BEAMS	40	40	40	40
COLUMNS	25	40		

- REINFORCEMENT SYMBOLS ARE AS FOLLOWS:
R - STRUCTURAL GRADE ROUND BARS (260 R)
N - HOT ROLLED DEFORMED BARS (500 N)
SL - HARD-DRAWN WIRE MESH REINFORCING FABRIC (500SL)



- ALL REINFORCEMENT TO BE ADEQUATELY SUPPORTED IN ITS REQUIRED POSITION BY CHAIRS, GENERALLY AT NOT GREATER THAN 900mm CENTRES BOTH WAYS.
- REINFORCEMENT SPLICES SHALL ONLY MADE AT THE POSITIONS SHOWN ON DRAWING OR BY WRITTEN APPROVAL OF ENGINEER. REINFORCEMENT LAPS IF REQUIRED SHALL BE ACCORDANCE WITH AS3800. UNLESS STATED OTHERWISE, LAPS AS BELOW:
 - TRENCH MESH AND FABRIC: 2 TRANSVERSE WIRES (FULL SQUARE MESH) PLUS 25mm
 - BARS AS BELOW:

REINF. BAR	LAP LENGTH
N12	500
N16	600
N20	750
N24	850
N28	1000

- FORMWORK SUPPORTING SUSPENDED SLABS, BEAMS, COLUMNS AND WALLS MUST BE LEFT IN POSITION FOR AT LEAST 21 DAYS AFTER CONCRETE IS POURED.
- NO HOLES OR CHASES OTHER THAN THOSE SHOWN ON THE STRUCTURAL DRAWINGS TO BE MADE IN CONCRETE MEMBERS WITHOUT PRIOR APPROVAL OF THE ENGINEER.
- ALL CONCRETE IN BEAMS, COLUMNS, SLABS AND WALLS SHALL BE VIBRATED MECHANICALLY DURING POURING.
- CURING THE CONCRETE SHALL START IMMEDIATELY AFTER FINISHING BY CONTINUALLY WETTING FOR 7 DAYS MINIMUM.
- BRITTLE FLOOR COVERINGS ARE TO BE LAID ON A SUITABLE, FLEXIBLE TYPE BEDDING SYSTEM AND SUPPLIED WITH CONTROL JOINTS AT 400mm CENTRES MAXIMUM. ALTERNATIVELY SL92 FABRIC CAN BE USED, OR DELAY APPLYING FINISHES FOR 3 MONTHS (REFER TO AS2870 OR AS3958).
- CONSTRUCTION JOINTS WHERE NOT SHOWN SHALL BE LOCATED TO THE APPROVAL OF ENGINEER.

PIERS

- THE ENGINEER IS TO INSPECT AND APPROVE PIERS BEFORE THE POURING OF CONCRETE.
- UNLESS NOTED OTHERWISE, MINIMUM PIER DEPTH IS 600mm BELOW FOOTING TRENCH AND WHEREVER NOMINATED SHOULD BE SOCKETED A MINIMUM 300mm INTO STIFF CLAY, 200mm INTO SHALE OR 100mm INTO ROCK DEPENDING ON THE BEARING CALLED UP .
- ALL PIER HOLES SHALL BE CLEANED AND DE-WATERED PRIOR TO THE POURING OF CONCRETE.
- ALL PIERS SHALL BE POURED SEPARATELY TO RAFT SLAB.
- IF ANY OF THE FOOTING BEAMS ENCOUNTER ROCK OR SHALE, THEN ALL BEAMS AND LOAD BEARING SPINE BEAMS SHALL BE PIERED TO ROCK OR SHALE. IF PARTIALLY PIERED TO ROCK THEN BRICK JOINTS ARE TO BE PROVIDED AT THE ROCK/ NON-ROCK INTERFACE.
- PIER DIAMETER AND LOCATIONS ARE SHOWN ON PLAN. ONLY WITH THE PRIOR APPROVAL OF THE ENGINEER MAY THE PIER DIAMETER BE VARIED AS PER THE "PIER DIAMETER TABLE" BELOW.

PIER DIAMETER TABLE			
STRATA	MIN. BEARING CAPACITY (kPa)	SINGLE STOREY	DOUBLE STOREY
STIFF CLAY	250	Ø400 @ 2.0m CTS U.N.O	Ø450 @ 2.0m CTS, OR Ø400 @ 1.5m CTS U.N.O
ROCK/SHALE	600	Ø400 @ 2.0m CTS U.N.O	Ø450 @ 2.0m CTS, OR Ø400 @ 1.5m CTS U.N.O

FOOTINGS AND FLOOR SLAB

- ALL WORKMANSHIP AND MATERIALS SHALL BE IN ACCORDANCE WITH AS3600.
- IT IS THE RESPONSIBILITY OF THE CONTRACTOR TO ENSURE PIER TOPS ARE CLEAN OF FOREIGN MATTER PRIOR TO THE PLACEMENT OF THE MEMBRANE AND CONCRETE SLAB. ENGINEER'S SPOT CHECK DOES NOT RELEASE THE CONTRACTOR FROM THIS RESPONSIBILITY.
- PIPES OR CONDUITS SHALL NOT BE PLACED WITHIN THE CONCRETE COVER TO REINFORCEMENT WITHOUT THE APPROVAL OF THE ENGINEER.
- PIPE PENETRATION IN THE EDGE AND SPINE BEAMS ARE TO BE CARRIED OUT IN ACCORDANCE WITH THE DETAILS. WHERE SLAB FABRIC IS CUT TO PERMIT PENETRATIONS OF PIPES, A 600 x 600mm PIECE OF FABRIC IS TO BE SPLICED OVER THE PENETRATION.
- FOR 'H' AND 'E' CLASS SITES, ALL PENETRATIONS THROUGH FOOTINGS AND EDGE BEAMS SHALL BE SLEAVED TO ALLOW MINIMUM 20mm ('H' CLASS) AND 40mm ('E' CLASS) MOVEMENT AS PER AS2870. ALL PLUMBING AND DRAINAGE SERVICES ARE TO BE FITTED WITH FLEXIBLE CONNECTIONS AS PER AS2870.
- SUBTERRANEAN TERMITE PROTECTION IS TO BE PROVIDED IN ACCORDANCE WITH THE REQUIREMENTS OF AS3660.
- A WATERPROOF MEMBRANE CONSISTING OF A 0.2mm NOMINAL THICKNESS POLYETHYLENE FILM, SHALL BE PLACED UNDER ALL SLABS & BEAMS U.N.O. IT SHALL BE HIGH IMPACT RESISTANT IN ACCORD WITH CLAUSES 5.3.3.2 AND 5.3.3.3 OF AS2870-2011.
- FOR SLAB ON GROUND: SERVICES TO BE PLACED IN A 300mm WIDE x 450mm DEEP TRENCH A MINIMUM OF 600mm FROM EDGE OF BUILDING TO AVOID UNDERMINING OF FOOTINGS.

TERMITE PROTECTION

- ALL WORKS TO BE IN ACCORDANCE WITH AS3660.1.
- ANY FUTURE CRACKING IN THE SLAB IS TO BE ASSESSED BY A QUALIFIED PEST EXPERT AND WERE DIRECTED, BE SEALED BY EPOXY INJECTION.

ISSUED FOR APPROVAL



Halina Engineers Pty Ltd
w: halina.com.au
e: harry@halina.com.au
t: 0402.296.323

rev. date Amendment
A 22/01/2024 ISSUED FOR APPROVAL

Client HEARN
Project LOT 2 DP1014531
87 HENRY BAYLY DRIVE
MUDGEE NSW 2850

Drawing title

GENERAL NOTES
PAGE 1

Original size A3

Job number

4829

sheet S01

rev. A

design draft

Approved by

BE(HONS) PHD CPEng NER

MASONRY

- LOAD BEARING MASONRY SHALL COMPLY WITH AS3700 AND THE PROJECT SPECIFICATIONS.
- THE MINIMUM CHARACTERISTIC COMPRESSIVE STRENGTH OF THE MASONRY UNITS AS DESCRIBED IN AS3700 SHALL BE 20MPa UNLESS NOTED OTHERWISE.
- MORTAR: MASONRY TO BE EMBEDDED IN FRESHLY PREPARED MORTAR.
- GROUT SHALL HAVE A COMPRESSIVE STRENGTH (F_c) OF 15MPa AT 28 DAYS. A SLUMP OF 125mm IN 150mm SLUMP CONE. A MAXIMUM AGGREGATE SIZE OF 10mm AND BE IN ACCORDANCE WITH AS3700 PART 1.
- MORTAR 1:1:6 PROPORTION BY VOLUME OF CEMENT, LIME AND SAND RESPECTIVELY.
- MASONRY SHALL BE ARTICULATED BY THE CONTRACTOR IN ACCORDANCE WITH THE BCA CLASS 1 AND 10 BUILDINGS, VOLUME 2.
- INTERNAL BRICKWORK BUILT OFF THE SLAB SHALL BE LAID ON TWO LAYERS OF 'ALCOR' OR SIMILAR SLIP JOINT MATERIAL. THE JOINT THICKNESS SHALL NOT EXCEED 12mm.
- MASONRY WALLS MUST NOT BE BUILT ON CONCRETE SLABS OR BEAMS UNTIL ALL FORMWORK/ PROPS SUPPORTING THESE SLABS AND BEAMS HAVE BEEN REMOVED.
- ALL WALL TIES TO BE BUILT IN AND FIXED TO FRAME PROGRESSIVELY AS CONSTRUCTION PROCEEDS SPACED AT EACH SIDE OF EXPANSION JOINTS AND AT EACH THIRD COURSE. THE SPACING OF ALL OTHER TIES SHALL BE AS DESCRIBED IN THE BCA CLASS 1 AND 10 BUILDINGS, VOLUME 2.

NON-LOAD BEARING BRICK WALL LINTEL NOTES

- ALL LINTELS TO BE HOT DIPPED GALVANIZED.
- PROVIDE 1 LINTEL TO EACH ALL LEAF, DO NOT CUT ON SITE. KEEP LINTELS 6mm CLEAR OF HEADS AND FRAMES. PACK MORTAR BETWEEN THE ANGLE UPSTAND. UNEQUAL ANGLE LINTELS SHOULD HAVE THEIR LONG LEG VERTICAL.
- LINTEL BEARING AT EACH SIDE:
 - SPAN LESS THAN 1800mm: MIN. 150mm BEARING
 - SPAN GREATER THAN 1800: MIN. 230mm BEARING.
- TO PREVENT DEFLECTION OR EXCESSIVE ROTATION, TEMPORARILY PROP PROPRIETARY COLD-FORMED LINTELS UNTIL MASONRY REACHES ITS REQUIRED STRENGTH. MINIMUM PROPPING PERIOD IS 3 DAYS.

BRICK LINTEL SCHEDULE			
OPENING SIZE	INTERNAL SKIN	EXTERNAL SKIN	END BEARING
(m) TO 900	100x6mm FLAT BAR	100x6mm FLAT BAR	100mm
1200	100x10mm FLAT BAR	100x8mm FLAT BAR	100mm
1500	100x8 EA	100x6 EA	150mm
2100	150x100x8 UA	150x100x6 UA	150mm
2400	150x100x8 UA	150x100x8 UA	150mm
2700	150x100x10 UA	150x100x10 UA	150mm
3000	150x100x12 UA	150x100x12 UA	150mm

STRUCTURAL STEELWORK NOTES

- ALL WORKMANSHIP AND MATERIALS SHALL BE IN ACCORDANCE WITH AS4100-1998.
- BUILDERS SHALL PREPARE WORKSHOP DRAWINGS AND SHALL SUBMIT THREE COPIES OF EACH DRAWINGS FOR CONDITIONAL APPROVAL. FABRICATION SHALL NOT COMMENCE UNTIL THIS APPROVAL HAS BEEN GIVEN.
- BOLTS NOT DESIGNATED SHALL BE GRADE 8.8/S BOLTS TO AS1252-1996, TIGHTENED TO A SNUG TIGHT FIT. BOLTS DESIGNATED 8.8/TF AND 8.8/TB SHALL BE HIGH STRENGTH STEEL BOLTS TO AS1252-1996, FULLY TENSIONED IN ACCORDANCE WITH AS4100-1998.
- WELDING SHALL BE PERFORMED BY AN EXPERIENCED OPERATOR IN ACCORDANCE WITH AS1554-2011.

- ALL WELDS SHALL BE GP (GENERAL PURPOSE) IN ACCORDANCE WITH AS1554-2011, USING NOMINAL TENSILE STRENGTH f_{uw} = 430MPa OR HIGHER TO AS4100-1998 UNLESS NOTED OTHERWISE.
- STEELWORK CONNECTIONS SHALL BE IN ACCORDANCE WITH THE FOLLOWING MINIMUM REQUIREMENTS UNLESS NOTED OTHERWISE.
 - ALL WELDS SHALL BE 6mm CONTINUOUS FILLET WELD ALL AROUND.
 - ALL BOLTS SHALL BE M20-8.8/S BOLTS, WITH A MINIMUM OF 2 BOLTS PER CONNECTION.
 - ALL GUSSET AND CLEAT PLATES SHALL BE 10mm THICK.
- THE ENDS OF ALL TUBULAR MEMBERS ARE TO BE SEALED WITH NOMINAL THICKNESS PLATES AND CONTINUOUS FILLET WELDED UNLESS OTHERWISE SHOWN. SUBSTITUTIONS FOR STEEL SECTIONS SHOWN ON DRAWINGS SHALL NOT BE MADE WITHOUT APPROVAL OF THE ENGINEER.
- AFTER PLUMBING AND LEVELING OF COLUMNS AND MULLIONS, INSTALL A PAD OF NON SHRINK GROUT BETWEEN THE TOP OF THE FOOTING AND THE UNDERSIDE OF THE PLATE AND STRIKE OFF THE GROUT AT 45°.
- CAMBER TO BE AS NOTED ON THE DRAWINGS.
- MEMBERS ENCASED IN CONCRETE, FIRE SPRAYED OR HSTF BOLTED CONNECTIONS MUST NOT BE PAINTED.
- CONCRETE ENCASED STEELWORK SHALL BE WRAPPED WITH SL62 MESH, UNLESS NOTED OTHERWISE.
- THE CONTRACTOR SHALL PROVIDE AND LEAVE IN PLACE UNTIL PERMANENT BRACING ELEMENTS ARE CONSTRUCTED SUCH TEMPORARY BRACING AS IS NECESSARY TO STABILIZE THE STRUCTURE DURING ERECTION.
- BEFORE FABRICATION IS COMMENCED THE CONTRACTOR SHALL SUBMIT COPIES OF THE SHOP DRAWINGS TO THE ENGINEER AND CLIENT FOR REVIEW. REVIEW DOES NOT INCLUDE CHECKING OF DIMENSIONS.

STRUCTURAL STEELWORK DURABILITY NOTES

- ATMOSPHERIC CORRISIVITY CATEGORY C3 TO AS4312-2008:
 - COVERED STEELWORK: CLASS 2.5 BLAST PLUS 75 MICRON EPOXY ZINC PHOSPHATE TO AS2312.1-2014.
 - EXPOSED STEELWORK: HDG600 TO AS4680-2006.
 - COLD FORMED STEELWORK: AZ150 OR AM150 TO AS1397-2011.
 - SCREWS TO BE CLASS 4 TO AS3566.2. BOLTS TO BE HDG TO AS1214.
 - MASONRY BOLTS TO HAVE MINIMUM 25 MICRONS ZINC COATING.

STRUCTURAL TIMBER NOTES

- ALL WORKMANSHIP AND MATERIALS SHALL BE IN ACCORDANCE WITH AS1684.1-1999, AS1684.2-2010, AS1170.0-2002, AS1170.1-2002 AS1170.2-2011, AS1170.3-2003, AS1170.4-2007 AS SPECIFIED IN CONTRACT DOCUMENTS.
- ALL TIMBER CONNECTIONS TO BE IN ACCORDANCE WITH AS1684 UNLESS NOTED OTHERWISE.
- ALL PROPRIETARY CONNECTORS AND FIXINGS ARE TO BE INSTALLED IN ACCORDANCE WITH MANUFACTURERS SPECIFICATIONS.
- ALL TIMBER MEMBERS SHALL BE MIN. F5 STRESS GRADE U.N.O HARDWOOD SHALL BE F11 GRADE OR BETTER.
- ALL LVL (LAMINATED VENEER LUMBER) USED SHALL COMPLY WITH AS4357 (STRUCTURAL LAMINATED VENEER LUMBER CODE) AND MUST BE INSTALLED AS PER MANUFACTURERS SPECIFICATION.
- MAXIMUM UNDERSIZE FOR ALL TIMBER MEMBERS SHALL BE AS FOLLOWS:
 - SEASONED PINE & OTHER SEASONED SOFTWOODS = 0mm
 - UNSEASONED HARDWOODS = 3mm
 - SEASONED HARDWOODS = 0mm
 - OREGON = 4mm
- TIMBER MEMBERS NOT SIZED OR SCHEDULED ON THE DRAWINGS SHALL BE SELECTED USING AS1684.1-1999.
- ALL TIMBER JOINTS ARE TO BE FREE OF DEFECTS.
- ALL NAILS, BOLTS AND SCREWS SHALL BE GALVANISED UNLESS APPROVED OTHERWISE BY THE SITE SUPERINTENDENT.

- TIMBER FLOORS IN WET AREAS (EG. BATHROOMS, LAUNDRIES) SHALL BE IN ACCORDANCE WITH THE BUILDING CODE OF AUSTRALIA.
- ALL EXPOSED TIMBER SHALL COMPLY WITH THE REQUIREMENTS OF APPENDIX C OF AS1684.2 (IE. PROVIDE PRESERVATIVE TREATMENT)
- TERMITE PROTECTION: ALL CONSTRUCTION WORK SHOULD BE IN ACCORDANCE WITH AS3660.1 PROTECTION OF BUILDINGS FROM SUBTERRANEAN TERMITES PART 1: NEW BUILDINGS. IF THE REQUIREMENTS IN THIS CODE ARE UNABLE TO BE MET, METRO CONSULTING GROUP RECOMMENDS THE USE OF TERMITE RESISTANT STRUCTURAL TIMBER IN ACCORDANCE WITH AS1604-1997 AS SHOWN BELOW:
 - ENVIRONMENT:
 - INTERIOR ABOVE GROUND: HAZARD LEVEL H2
 - EXTERIOR ABOVE GROUND: HAZARD LEVEL H3.
 - EXTERIOR IN GROUND: HAZARD LEVEL H4 & H5.
- U.N.O, ALL LINTELS (NOT SUPPORTING CONCENTRATED LOADS SUCH AS HANGING/STRUTTING BEAMS, GIRDER TRUSSES ETC.) TO BE AS FOLLOWS:

TILED ROOF TIMBER LINTEL SCHEDULE	
SPAN	LINTEL SIZE & GRADE
900	100x50 - F7 OR MGP10
1200	150x75 - F7 OR MGP10
1500	150x75 - F7 OR MGP10
1800	200x75 - F7 OR MGP10
2100	250x50 - F7 OR MGP10
2400	250x75 - F7 OR MGP10
2700	300x75 - F7 OR MGP10
3000	2/250x45 - F7 OR MGP10
3600	2/300x45 - F7 OR MGP10

SHEETED ROOF TIMBER LINTEL SCHEDULE	
SPAN	LINTEL SIZE & GRADE
900	100x50 - F7 OR MGP10
1200	125x50 - F7 OR MGP10
1500	150x50 - F7 OR MGP10
1800	175x75 - F7 OR MGP10
2100	200x75 - F7 OR MGP10
2400	225x75 - F7 OR MGP10
2700	275x75 - F7 OR MGP10
3000	300x50 - F7 OR MGP10
3600	300x75 - F7 OR MGP10

- FIX BOTTOM OF STUD WALLS TO THE FLOOR AT 900 CTS. EITHER SIDE OF OPENINGS AND AT BASE OF ALL BRACING LOCATIONS TO SLAB WITH 1M12 DYNABOLT OR EQUIVALENT.
- UNLESS NOTED OTHERWISE, PROVIDE DOUBLE STUDS OR 90x90 MGP10 TIMBER POST UNDER THE END OF ALL BEAMS, LINTELS, STRUTS & GIRDER TRUSSES.
- THE BUILDER IS RESPONSIBLE FOR ADEQUATE TIE DOWN OF ALL ROOF MEMBERS TO THE FLOOR STRUCTURE AND FLOOR STRUCTURE TO FOUNDATIONS IN ACCORDANCE WITH AS1684.
- TYPICALLY ALL RAFTERS TO BE CONNECTED TO THE TOP PLATE WITH PROPRIETARY CONNECTORS SUCH AS METAL TRIP "L" GRIPS OR APPROVED CONNECTED TO BOTTOM PLATE. BOTTOM PLATE TO BE CONNECTED TO THE FLOOR FRAMING.
- ALL ROOF BEAMS TO BE TIED DOWN BY STRAP TO THE WALL IN ACCORDANCE WITH AS1684.
- ALL BRACING WALLS TO BE CONNECTED TO THE FLOOR STRUCTURE IN ACCORDANCE WITH ASS1684.

ISSUED FOR APPROVAL



Halina Engineers Pty Ltd
 w: halina.com.au
 e: harry@halina.com.au
 t: 0402.296.323

rev.	date	Amendment
A	22/01/2024	ISSUED FOR APPROVAL

Client HEARN
 Project LOT 2 DP1014531
 87 HENRY BAYLY DRIVE
 MUDGEE NSW 2850

Drawing title
 Original size **A3**

GENERAL NOTES
 PAGE 2

Job number	4829		Approved by
sheet	S02	rev.	A
design	draft	HA NGUYEN BE(HONS) PHD CPEng NER	

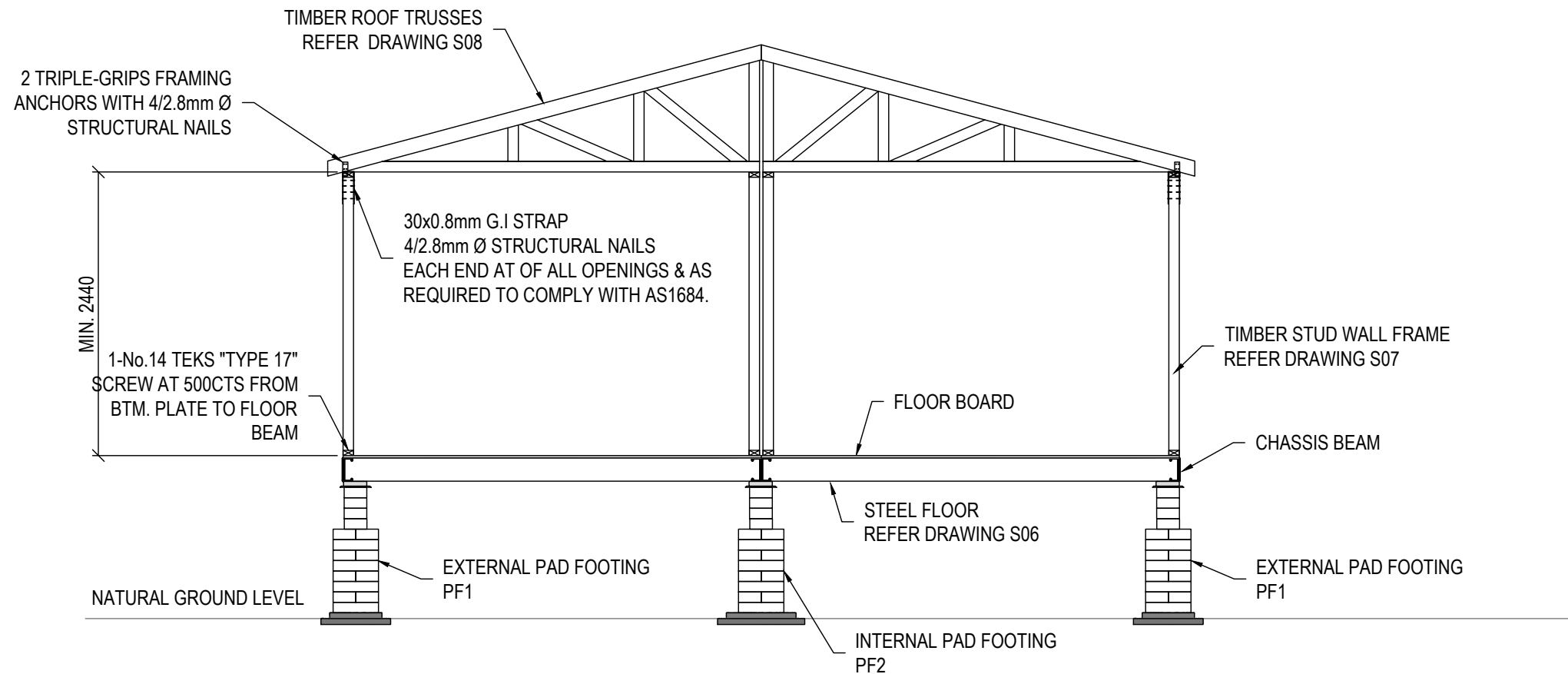

TYPICAL CROSS BUILDING SECTION

SCALE = 1:50

LOADING NOTES - ACCORDING TO AS1170.0, AS1170.1 & AS1170.2 (OR AS4055-2012)		
LOADING TYPE	LOADINGS	DESCRIPTIONS
DEAD LOAD - ROOF	0.3kPa	SELF-WEIGHT OF TIMBER OR STEEL ROOF FRAMES, METAL SHEETING AND MAX. 13mm PLASTERBOARD CEILING
DEAD LOAD - WALL	0.5kPa	SELF-WEIGHT OF TIMBER OR STEEL STUD FRAMES, GYPROCK
DEAD LOAD - FLOOR	0.75kPa	SELF-WEIGHT OF STEEL FLOOR FRAMES, FLOOR PARTICLE BOARD AND TIMBER/CARPET FINISHES.
LIVE LOAD - ROOF	0.25kPa	RESIDENTIAL NON-TRAFFICABLE ROOF LIVE LOAD
LIVE LOAD - FLOOR	1.5kPa	INTERNAL FLOOR - RESIDENTIAL LIVE LOAD.
	1.5kPa FOR DECK HEIGHT NOT OVER 1.0m ABOVE GROUND AND 2.0kPa FOR DECK WITH HEIGHT >1.0m ABOVE GROUND.	EXTERNAL FLOOR (DECK) - RESIDENTIAL LIVE LOAD.

WIND LOAD	REFER STRUCTURAL DESIGN CERTIFICATE	
SNOW LOAD	REFER STRUCTURAL DESIGN CERTIFICATE	

TRANSPORTATION NOTES:

1. THE DWELLING FRAME IS STRUCTURALLY ADEQUATE TO BE TRANSPORTED TO THE SITE. THE MAX. SPEED FOR TRANSPORTATION TO BE 80Km/h.
2. THE METHODOLOGY OF LIFTING AND INSTALLATION BY CRANE ON SITE BY OTHERS.

ISSUED FOR APPROVAL



Halina Engineers Pty Ltd
 w: halina.com.au
 e: harry@halina.com.au
 t: 0402.296.323

rev.	date	Amendment
A	22/01/2024	ISSUED FOR APPROVAL

Client HEARN
 Project LOT 2 DP1014531
 87 HENRY BAYLY DRIVE
 MUDGEE NSW 2850

Drawing title
 TYPICAL BUILDING CROSS SECTION
 Original size **A3**

Job number	4829	Approved by	
sheet	S03	rev.	A
design		draft	
		HA NGUYEN BE(HONS) PHD CPEng NER	

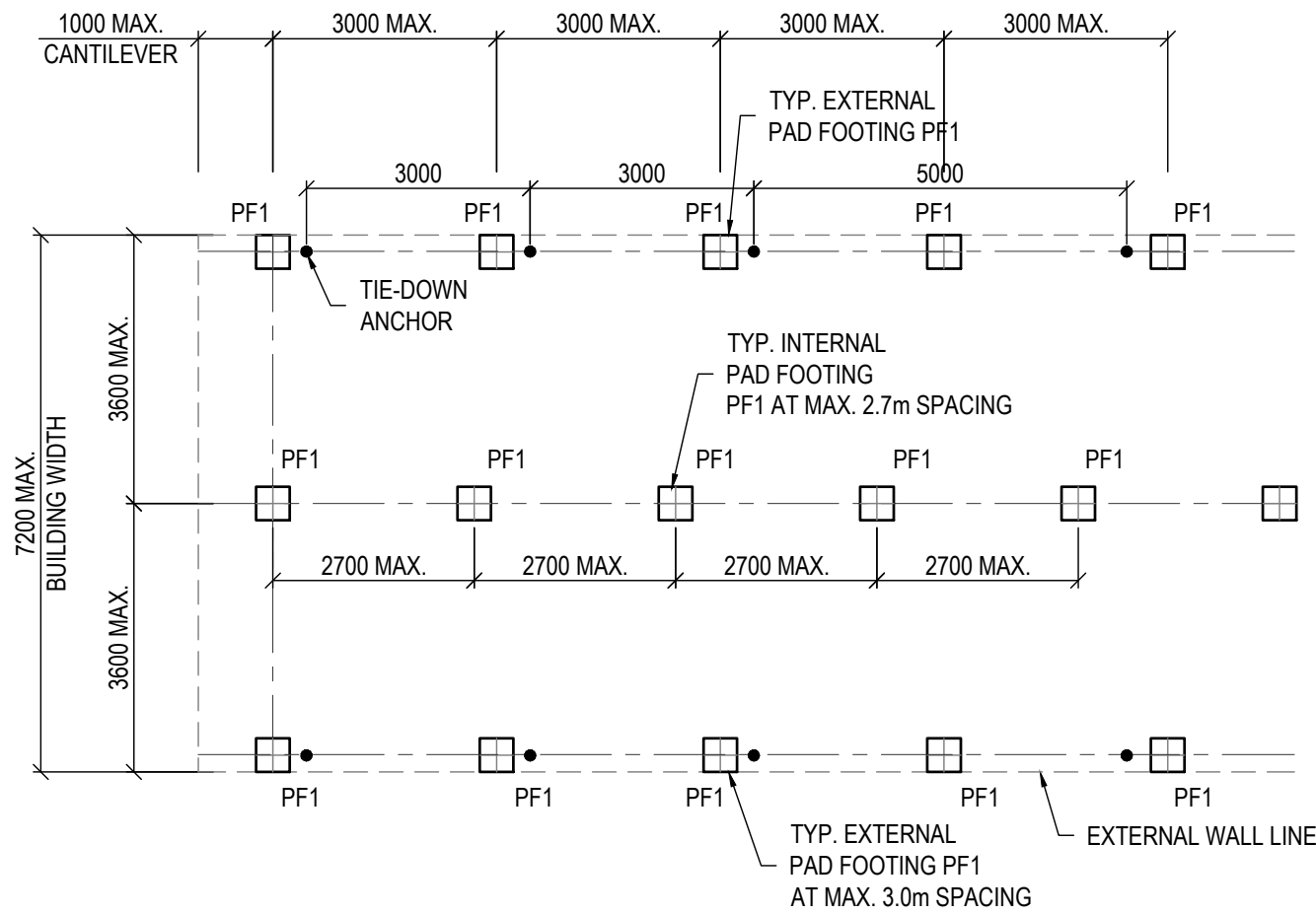

7.2m MAX. BUILDING WIDTH

PAD FOOTING LAYOUT

SCALE = 1:100

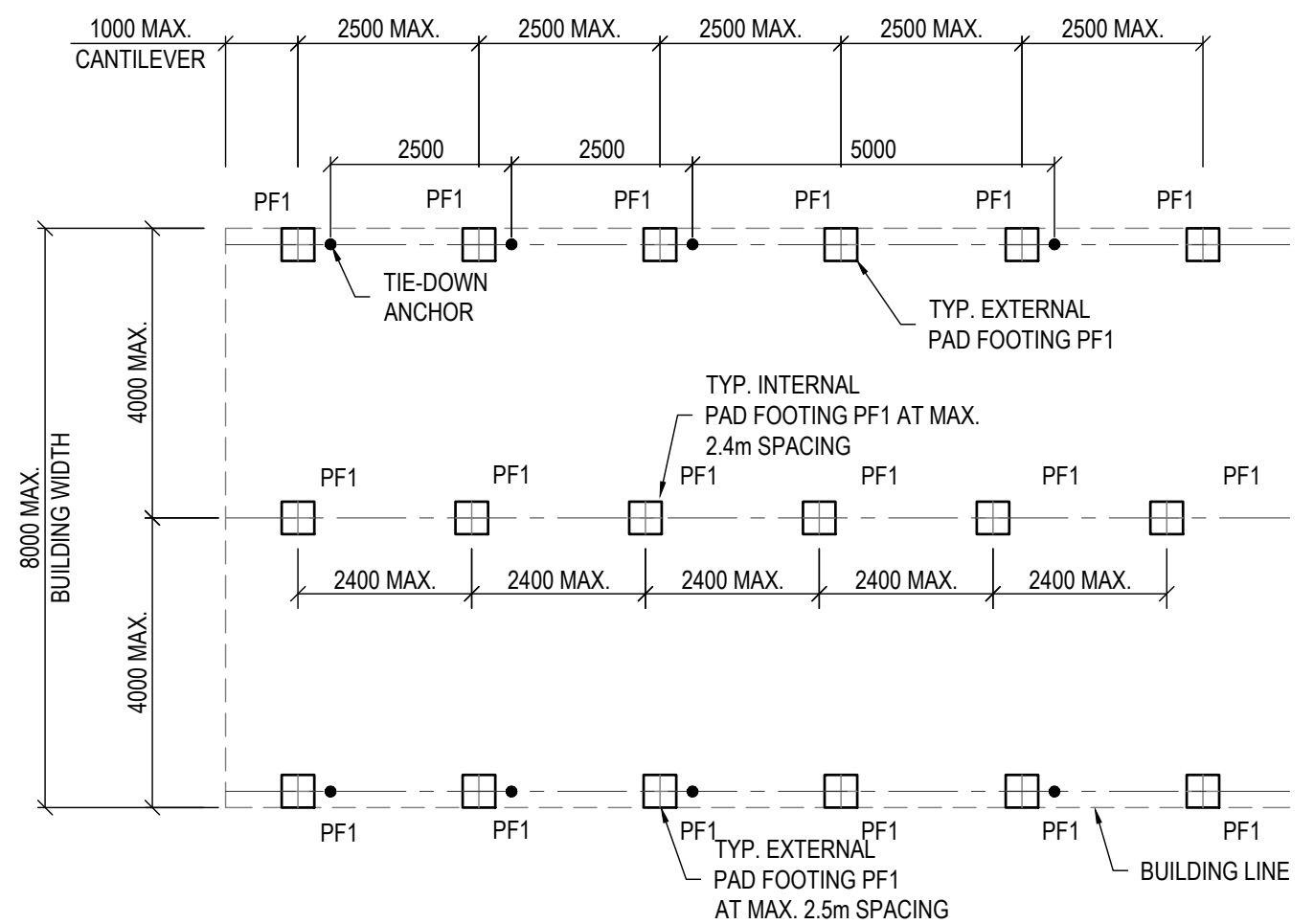

8.0m MAX. BUILDING WIDTH

PAD FOOTING PLAN

SCALE = 1:100

GEOTECHNICAL NOTES

SOIL CLASSIFICATION	ASSUMED SOIL CLASSIFICATION "M" TO AS2870-2011 WITH MIN. ALLOWABLE SOIL BEARING CAPACITY AT PAD BASE OF 100KPA. TO BE CONFIRMED ON SITE PRIOR TO CONSTRUCTION.
----------------------------	---

PAD FOOTING NOTES

MARK	SIZE	RE-MARK
PF1	450x450SQ x 50mm DEPTH CONCRETE PAD	PAD FOOTINGS, PRECAST CONCRETE 44MPa, SL62 MESH CENTRES.

ISSUED FOR APPROVAL



Halina Engineers Pty Ltd
 w: halina.com.au
 e: harry@halina.com.au
 t: 0402.296.323

rev.	date	Amendment
A	22/01/2024	ISSUED FOR APPROVAL

Client HEARN
 Project LOT 2 DP1014531
 87 HENRY BAYLY DRIVE
 MUDGEE NSW 2850

Drawing title
PAD FOOTING & ANCHOR LAYOUT
 Original size **A3**

Job number	4829		Approved by
sheet	S04	rev. A	
design		draft	
			HA NGUYEN BE(HONS) PHD CPEng NER

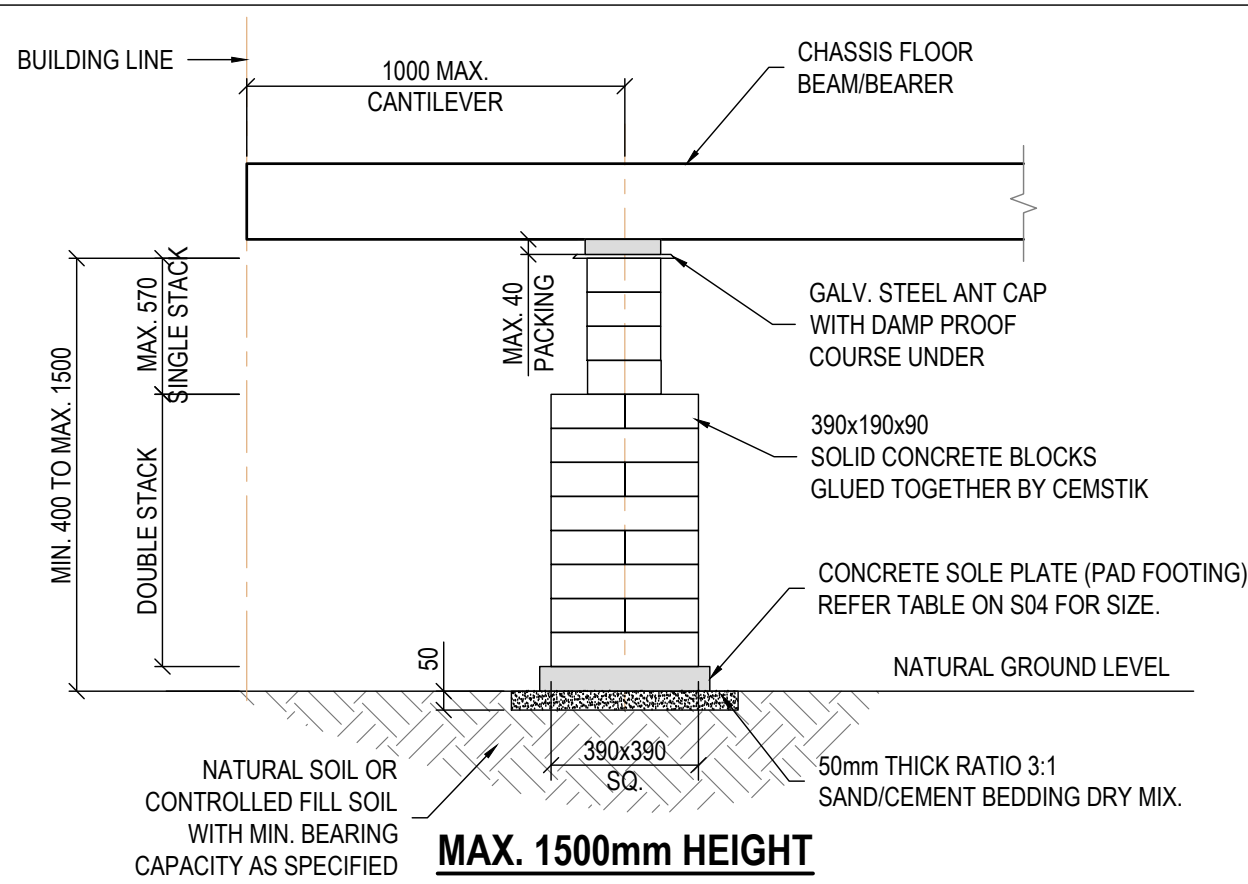

MAX. 1500mm HEIGHT

PAD FOOTING

SCALE = 1:100

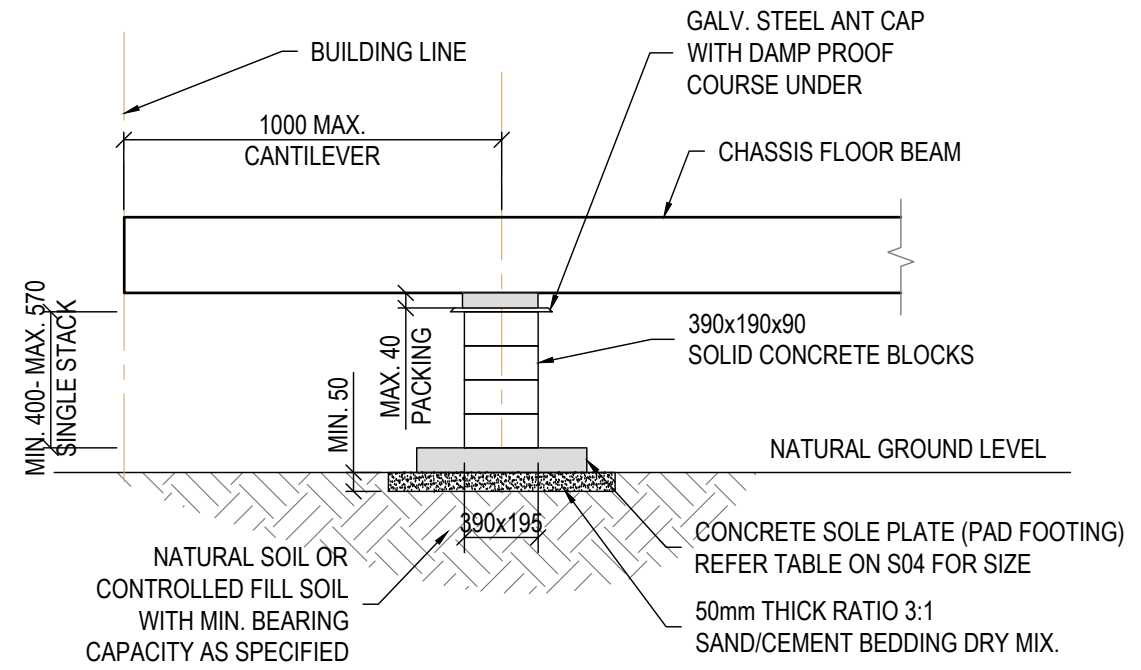

MAX. 570mm HEIGHT

PAD FOOTING

SCALE = 1:100

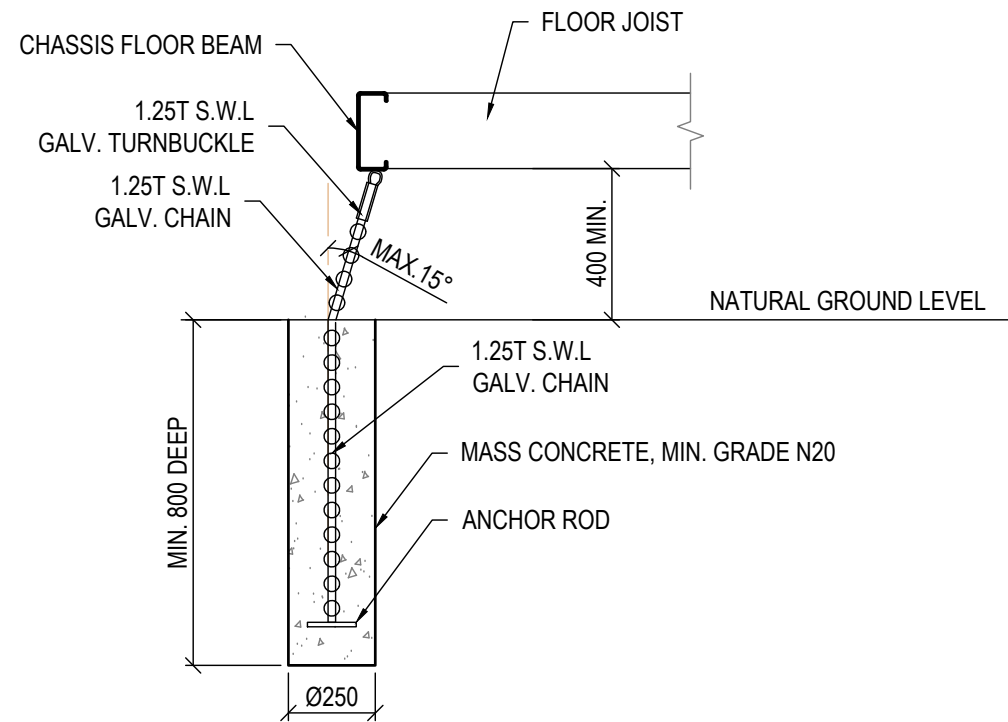

TIE-DOWN DETAIL "A"

SCALE = 1:100

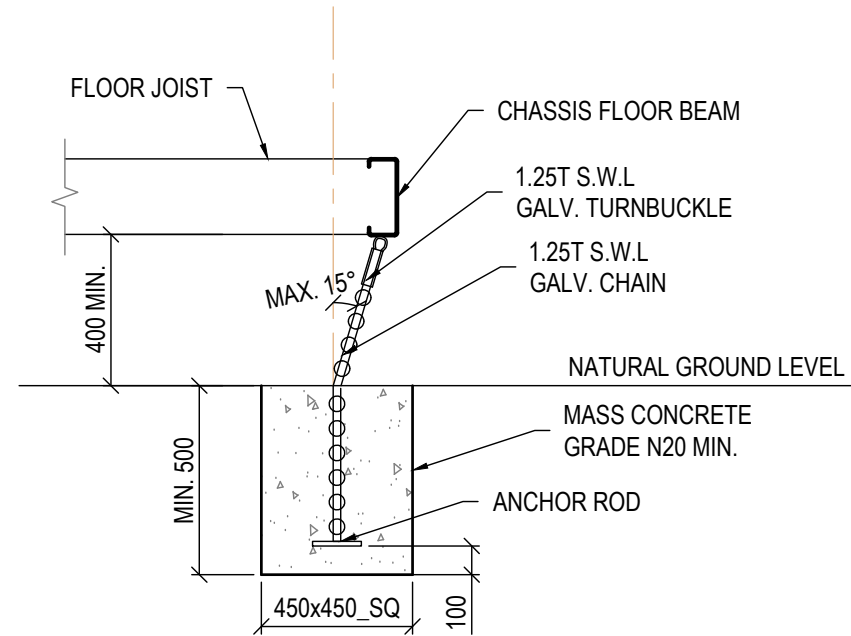

TIE-DOWN DETAIL "B"

SCALE = 1:100

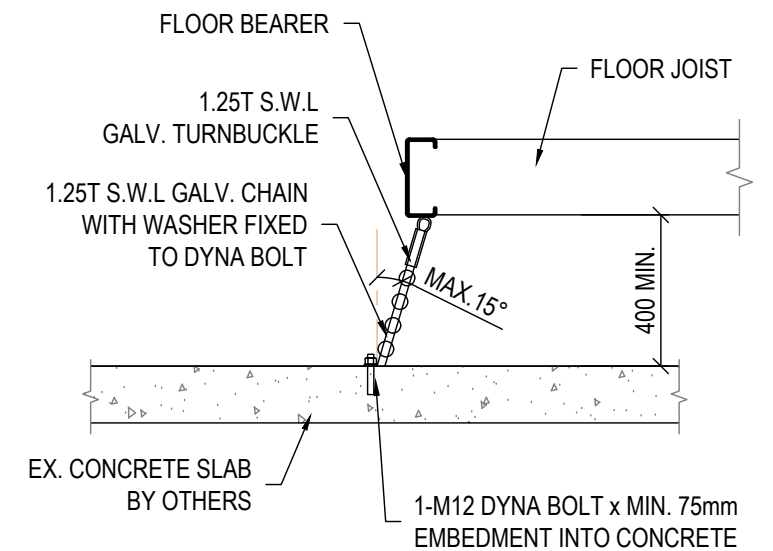

FIXING TO EX. CONCRETE SLAB

TIE - DOWN DETAIL

SCALE = 1:20



Halina Engineers Pty Ltd
 w: halina.com.au
 e: harry@halina.com.au
 t: 0402.296.323

rev.	date	Amendment
A	22/01/2024	ISSUED FOR APPROVAL

Client HEARN
 Project LOT 2 DP1014531
 87 HENRY BAYLY DRIVE
 MUDGEE NSW 2850

Drawing title
 TYPICAL FOOTING & ANCHOR DETAILS
 Original size A3

ISSUED FOR APPROVAL			
Job number	4829		Approved by
sheet	S05	rev. A	HA NGUYEN BE(HONS) PHD CPEng NER
design	draft		

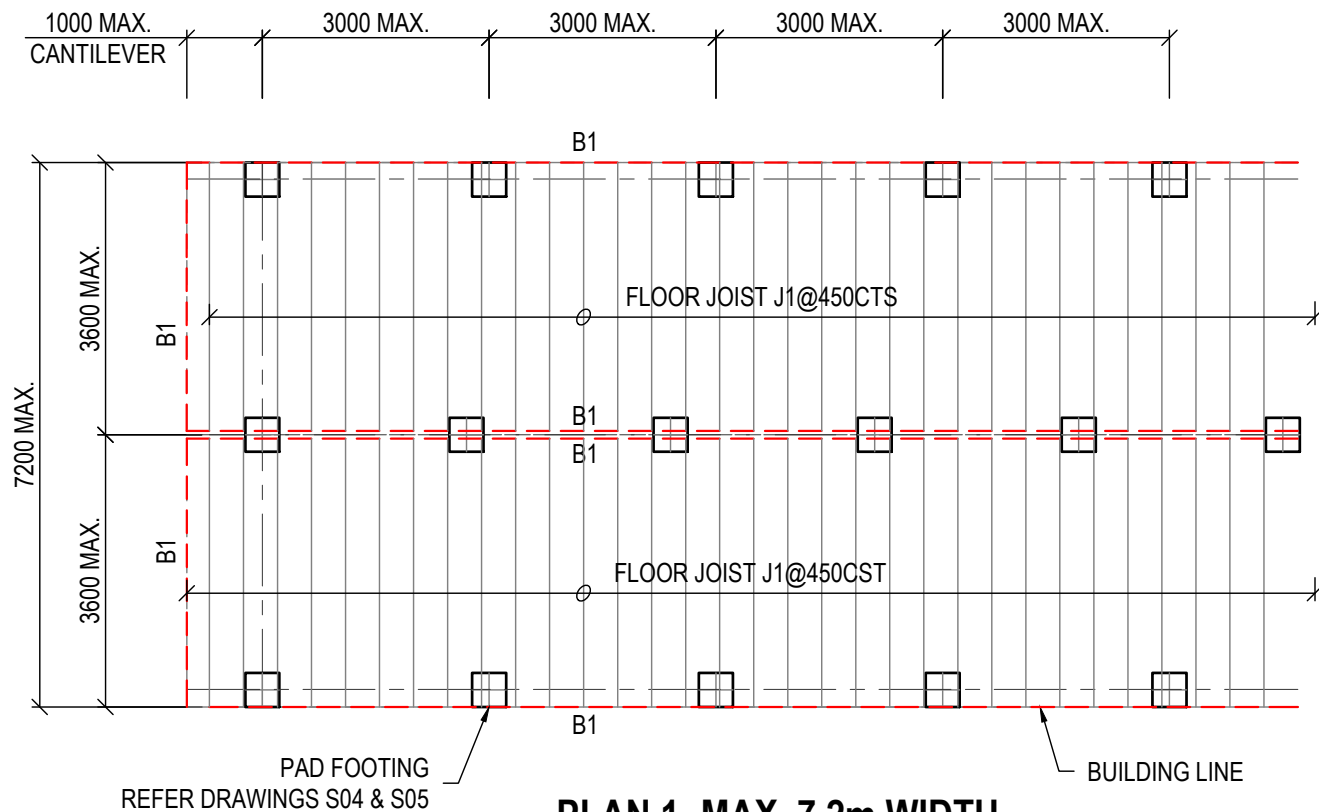

PLAN 1- MAX. 7.2m WIDTH
FLOOR FRAME
 SCALE = 1:100

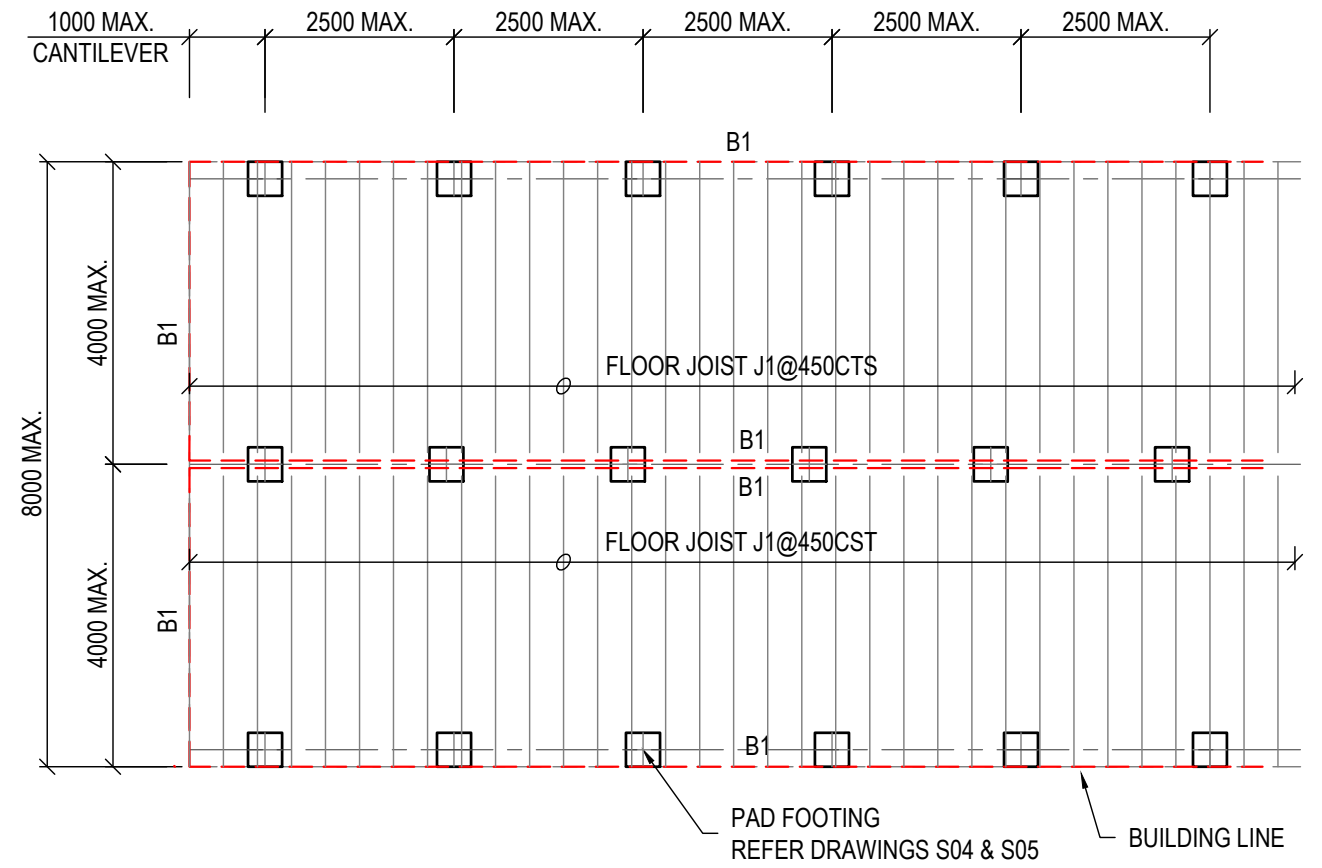

PLAN 2 - 8.0m MAX. BUILDING WIDTH
FLOOR FRAME
 SCALE = 1:100

FLOOR FRAME MEMBER LIST - PLAN 1 & PLAN 2		
MARK	SIZE	RE-MARK
J1	C200-15	FLOOR JOIST, C-SECTION GRADE 450, AT MAX. 450mm MAX. SPACING.
B1	C200-19	FLOOR BEARER, C-SECTION GRADE 450.

ISSUED FOR APPROVAL

Job number	4829	Approved by	
sheet	S06	rev.	A
design	draft		

HA NGUYEN
BE(HONS) PHD CPEng NER

30x0.8mm METAL STRAP LOOPED OVER THE TOP PLATE AND FIXED TO STUD WITH 4/2.8mmØ FLATHEAD GAL. NAILS EACH END

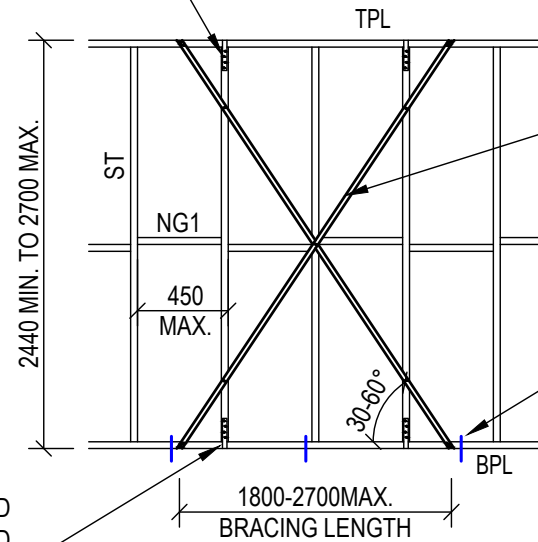

30x0.8mm (OR EQUIVALENT) TENSIONED GAL. METAL STRAPS, NAILED TO TOP AND BTM. PLATES WITH 4/2.8Ø FLAT HEAD GALV. NAILS. FIX STRAP TO STUDS WITH 1/Ø2.8 FLAT HEAD GALV. NAIL AT EACH STUD

1M10x60 DYNA BOLT TO CONCRETE SLAB OR 4-No.12 TEKS SCREWS THROUGH FROM BTM PLATE TO FLOOR JOIST AT EITHER END OF BRACE AND AT MAX. 1200CTS SPACING

30x0.8mm METAL STRAP LOOPED OVER THE BTM. PLATE AND FIXED TO STUD WITH 4/2.8mmØ FLATHEAD GAL. NAILS EACH END

**TYPICAL METAL STRAP
CROSSED WALL BRACING**

SCALE = 1:50

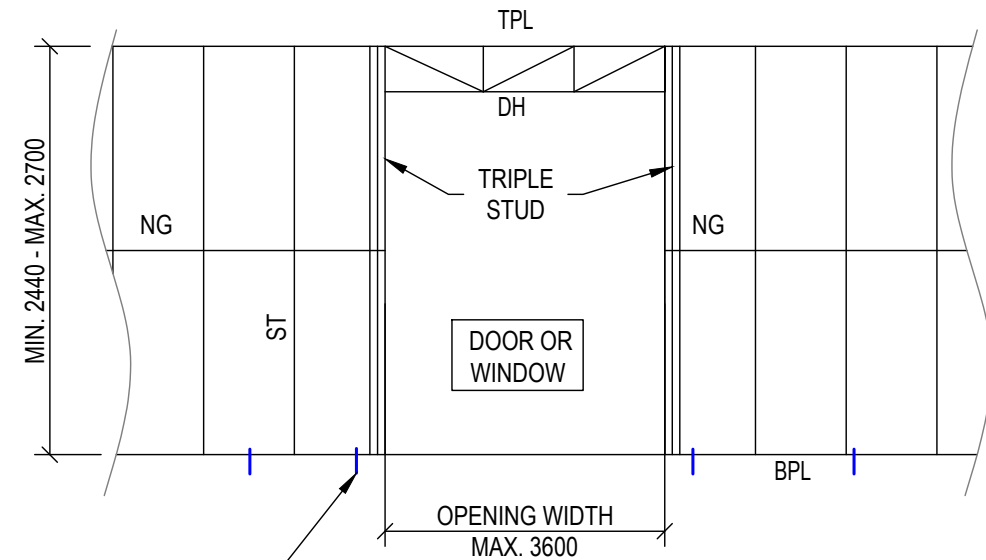

1M10x60 DYNA BOLT TO CONCRETE SLAB OR 4-No.12 TEKS SCREWS THROUGH FROM BTM PLATE TO FLOOR JOIST AT EITHER END OF OPENING AND AT MAX. 1200CTS SPACING

EXTERNAL WALL WITH OPENING

TYPICAL DETAIL

SCALE = 1:50

NOTES:

1. WALL FRAME CONNECTIONS AS PER AS1684.2-2010
2. WALL FRAME RACKING FORCE AND BRACING AS PER AS1684.2-2010.

WALL FRAMES		
MARK	SIZE	REMARK
TPL	90x35	TOP PLATE, TIMBER MGP10, H2 TREATED
ST	90x35	WALL STUD, TIMBER MGP10, H2 TREATED, AT MAX. 450CTS SPACING.
BPL	90x35	BOTTOM PLATE, TIMBER MGP10, H2 TREATED
NG	90x35	NOGGING, TIMBER MGP10, H2 TREATED
DH		DOOR HEAD, FOR WIND CLASSIFICATION N2
	90x45_MGP10	FOR OPENING WIDTH OF 2.0m MAX.
	2/90x45_MGP10	FOR OPENING WIDTH FROM 2.0m TO 2.8m
	2/170x45_MGP10	FOR OPENING WIDTH FROM 2.8m TO 3.6m

BRACING CAPACITY TABLE		
BRACING TYPE	CAPACITY	NOTES
4mm PLYWOOD - HARDBOARD grade F22	5.0kN/m	BRACING TO BE DESIGNED AND FIXED ACCORDING TO AS1684.2-2010.
30x0.8 METAL STRAP CROSSED BRACING	3.0kN/m	BRACING TO BE DESIGNED & FIXED ACCORDING TO AS1684.2-2010.

ISSUED FOR APPROVAL



Halina Engineers Pty Ltd
w: halina.com.au
e: harry@halina.com.au
t: 0402.296.323

rev.	date	Amendment
A	22/01/2024	ISSUED FOR APPROVAL

Client HEARN
Project LOT 2 DP1014531
87 HENRY BAYLY DRIVE
MUDGEE NSW 2850

Drawing title
TYPICAL WALL FRAME DETAILS

Original size A3

Job number	4829	Approved by	
sheet	S07	rev.	A
design		draft	

HA NGUYEN
BE(HONS) PHD CPEng NER

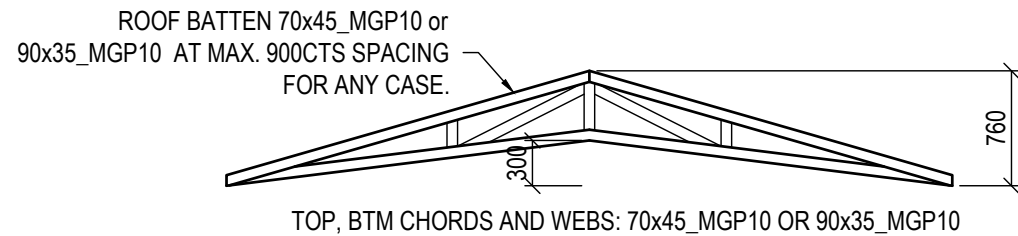

1. TRUSS AT MAX. 600mm SPACING TYPICALLY.
2. TRUSS SPACING =450mm FOR GROUND SNOW LOAD UP TO 1.5kPa.

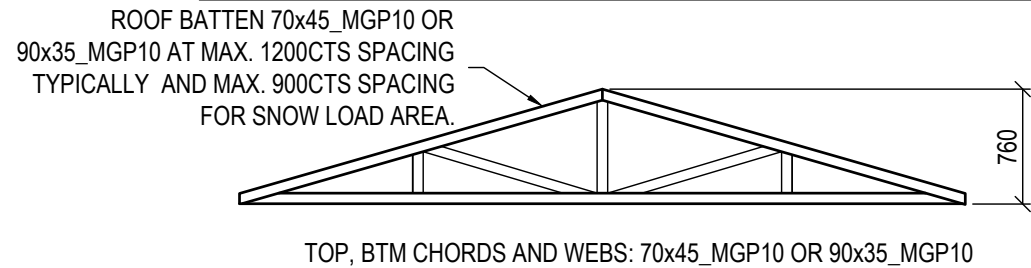

1. TRUSS AT MAX. 600mm SPACING FOR GROUND SNOW LOAD UP TO 1.8kPa.
2. TRUSS SPACING =450mm FOR GROUND SNOW LOAD FROM 1.8kPa TO 2.2kPa.

MAX. 4800mm SINGLE SPAN - TYPICAL TRUSS

SCALE = 1:50

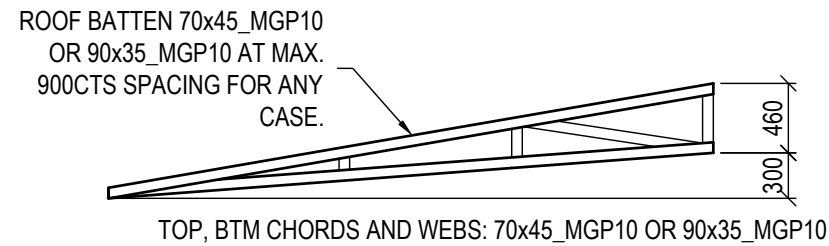

1. TRUSS AT MAX. 600mm SPACING TYPICALLY.
2. TRUSS SPACING =450mm FOR GROUND SNOW LOAD UP TO 1.5kPa.

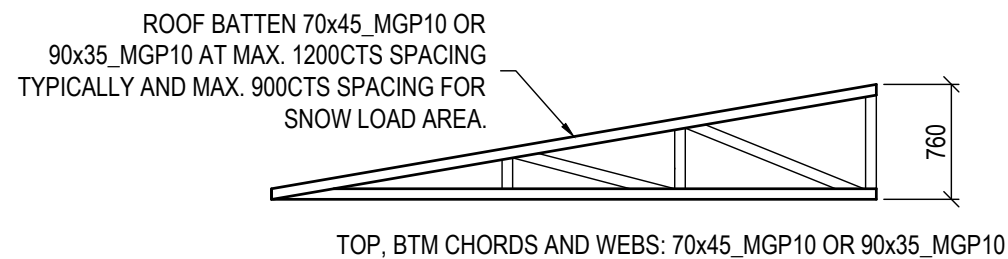

1. TRUSS AT MAX. 600mm SPACING FOR GROUND SNOW LOAD UP TO 1.8kPa.
2. TRUSS SPACING =450mm FOR GROUND SNOW LOAD FROM 1.8kPa TO 2.2kPa.

DOUBLE SPAN ROOF

MAX. 4000mm SPAN - TYPICAL TRUSS

SCALE = 1:50

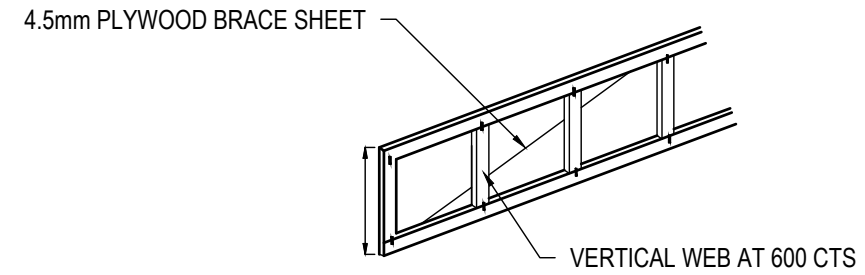

RIDGE TRUSS BEAM	
SPAN	TRUSS DEPTH
5400mm	600mm
6600mm	760mm

TOP, BTM CHORDS AND WEBS: 70x35_MGP10 OR 90x35_MGP10

RIDGE BEAM DETAIL

SCALE = 1:50

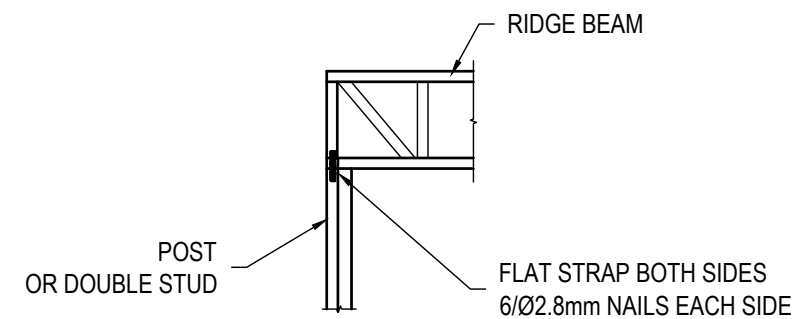

RIDGE BEAM TO POST CONNECTION

SCALE = 1:50

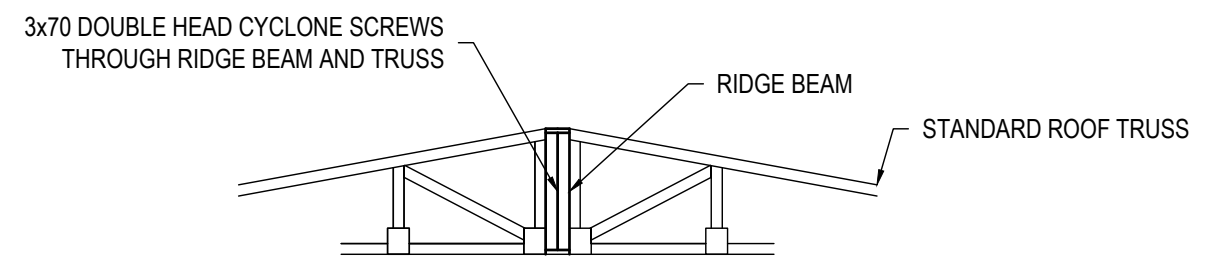

RIDGE BEAM TO TRUSS CONNECTION

SCALE = 1:50

ISSUED FOR APPROVAL



Halina Engineers Pty Ltd
w: halina.com.au
e: harry@halina.com.au
t: 0402.296.323

rev.	date	Amendment
A	22/01/2024	ISSUED FOR APPROVAL

Client HEARN
Project LOT 2 DP1014531
87 HENRY BAYLY DRIVE
MUDGEE NSW 2850

Drawing title
TYPICAL ROOF FRAME DETAILS
Original size A3

Job number	4829	Approved by	
sheet	S08	rev.	A
design		draft	
HA NGUYEN BE(HONS) PHD CPEng NER			