



**BARNSON PTY LTD**

**t** 1300 BARNSON (1300 227 676)

**e** [generalenquiry@barnson.com.au](mailto:generalenquiry@barnson.com.au)

**w** [www.barnson.com.au](http://www.barnson.com.au)

**Bathurst | Dubbo | Mudgee | Sydney | Tamworth**

# FOOTINGS DESIGN

Client:

**MID WESTERN REGIONAL COUNCIL**

Project Address:

**RYLSTONE CARAVAN PARK**

**CARWELL STREET, RYLSTONE, NSW 2849**

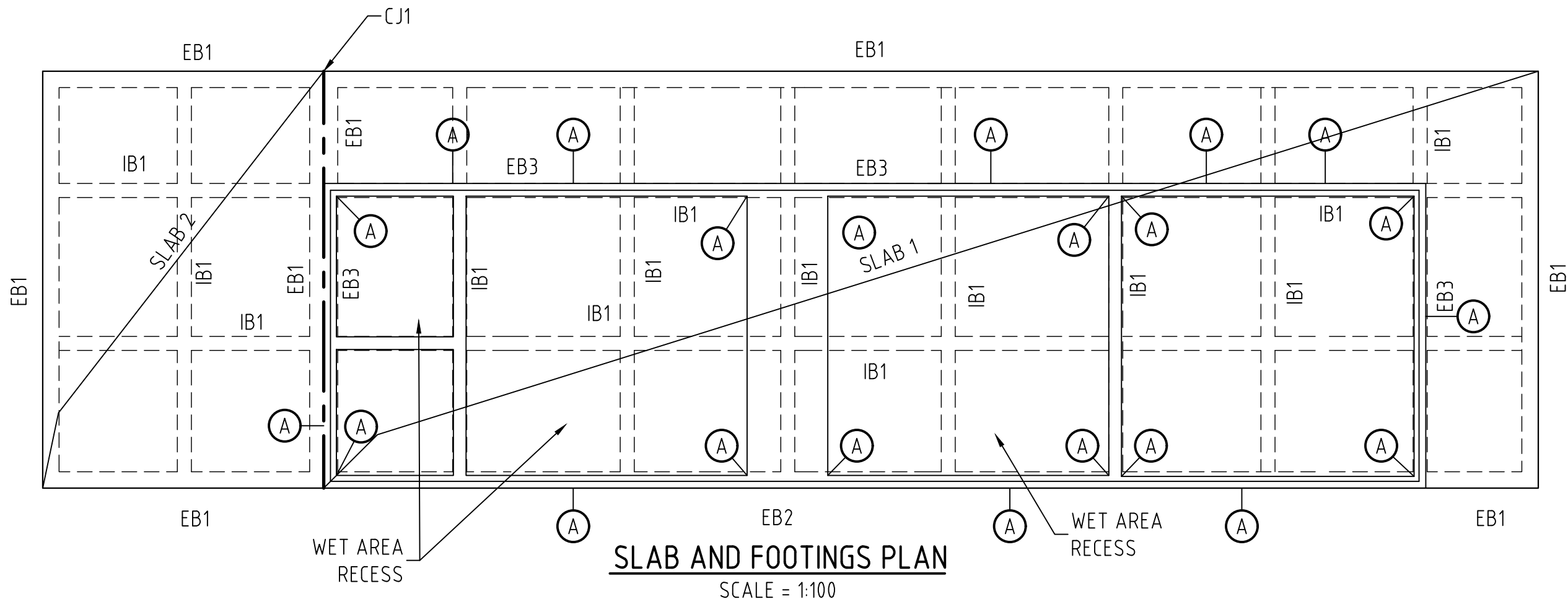

(A) ARTICULATION JOINTS TO POWER PANEL SPECIFICATION

**GEOTECHNICAL NOTES**

1. THESE SLABS AND FOOTINGS HAVE BEEN DESIGNED FOR A CLASS "P" SITE AND SOIL CLASS "M-D" AS DEFINED BY AS2870-2011, BASED UPON GEOTECHNICAL REPORT BY BARNSON PTY LTD, REFERENCE 36407-GR01\_A DATED 13/05/2021.

2. DUE TO EFFECT OF NEARBY TRESS, SEASONAL MOVEMENT IS 55-60mm PER APPENDIX H AS 2870-2011

**RAFT SLAB NOTES**

- A) SLAB 1&2
1. CONCRETE EXPOSURE CLASSIFICATION = A2 TO AS3600-2018
  2. 100mm THICK SLAB REINFORCED WITH ONE LAYER SL82 MESH TOP WITH 30mm COVER, BEAM BTM REINFORCEMENT AS SPECIFIED WITH 55mm COVER.
  3. CONCRETE IS TO BE GRADE N25 (25 MP<sub>a</sub> STRENGTH AT 28 DAYS)
  4. BASE PREPARATION: MIN. 200mm HARD-CORE BASE (DGB20 OR SIMILAR APPROVED) COMPACTED IN 150mm LAYERS TO 98% STANDARD COMPACTION.

5. A WATERPROOF MEMBRANE CONSISTING OF A 0.2mm NOMINAL THICKNESS POLYETHYLENE FILM, SHALL BE PLACED UNDER ALL SLABS & BEAMS U.N.O. IT SHALL BE HIGH IMPACT RESISTANT IN ACCORD WITH CLAUSES 5.3.3.2 AND 5.3.3.3 OF AS2870-2011.
6. SERVICES TO BE PLACED IN A 300mm WIDE x 450mm DEEP TRENCH A MINIMUM OF 600mm FROM EDGE OF BUILDING TO AVOID UNDERMINING OF FOOTINGS.

B) THIS PLAN SHALL BE READ IN CONJUNCTION WITH THE FOLLOWING REFERENCE DRAWINGS WHICH FORM PART OF THE PROJECT SPECIFICATION:  
G1000, G1001, G1002, G1003, G1004, G1005, G1006, G1007 AND S02 .

**ISSUED FOR APPROVAL**

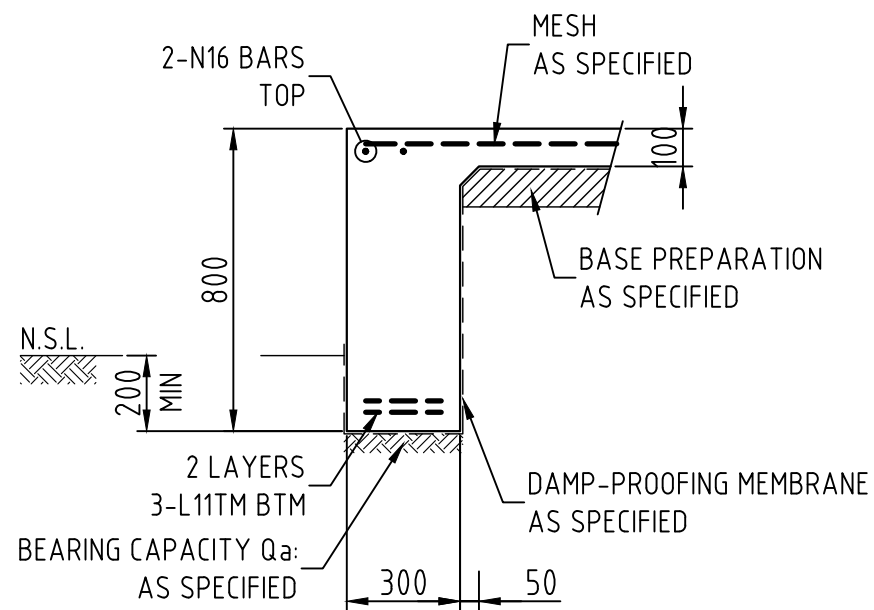

**EB1**  
SCALE = 1:20

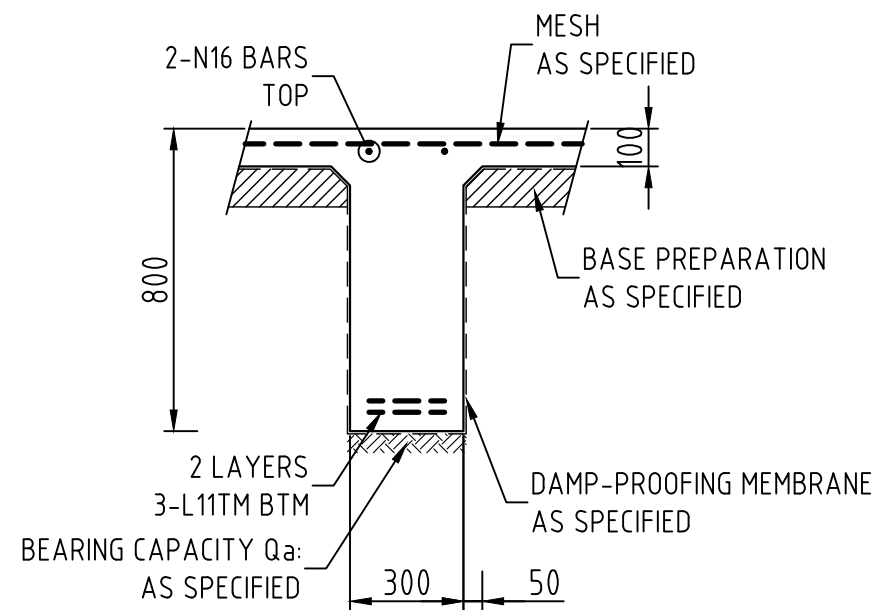

**IB1**  
SCALE = 1:20

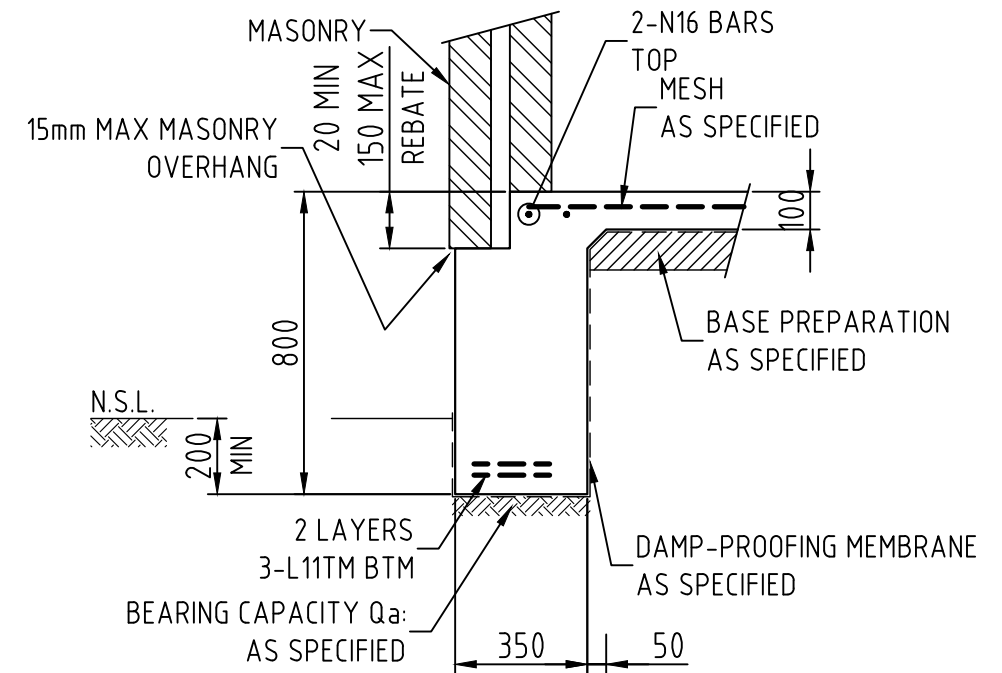

**EB2**  
SCALE = 1:20

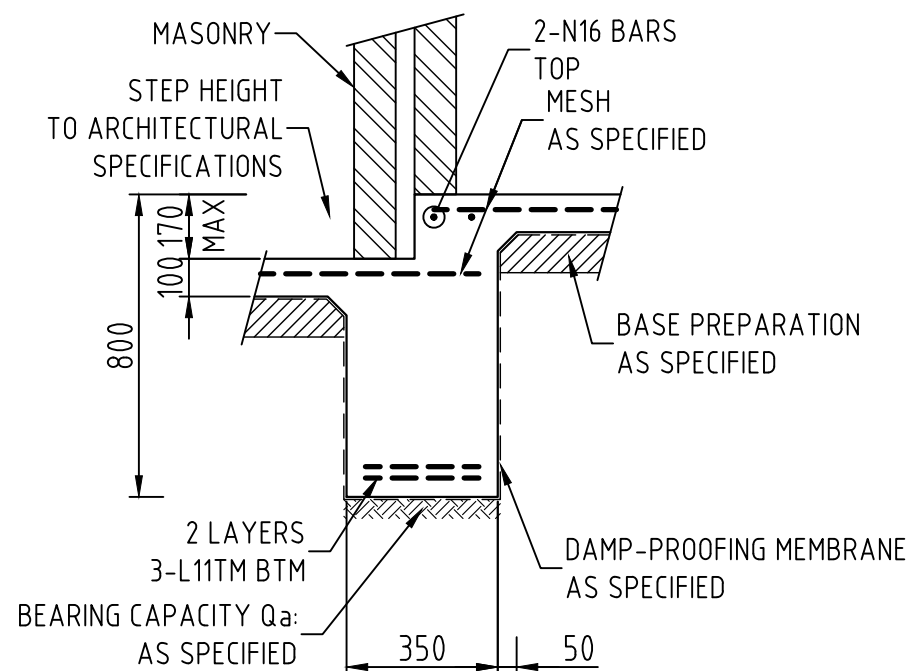

**EB3**  
SCALE = 1:20

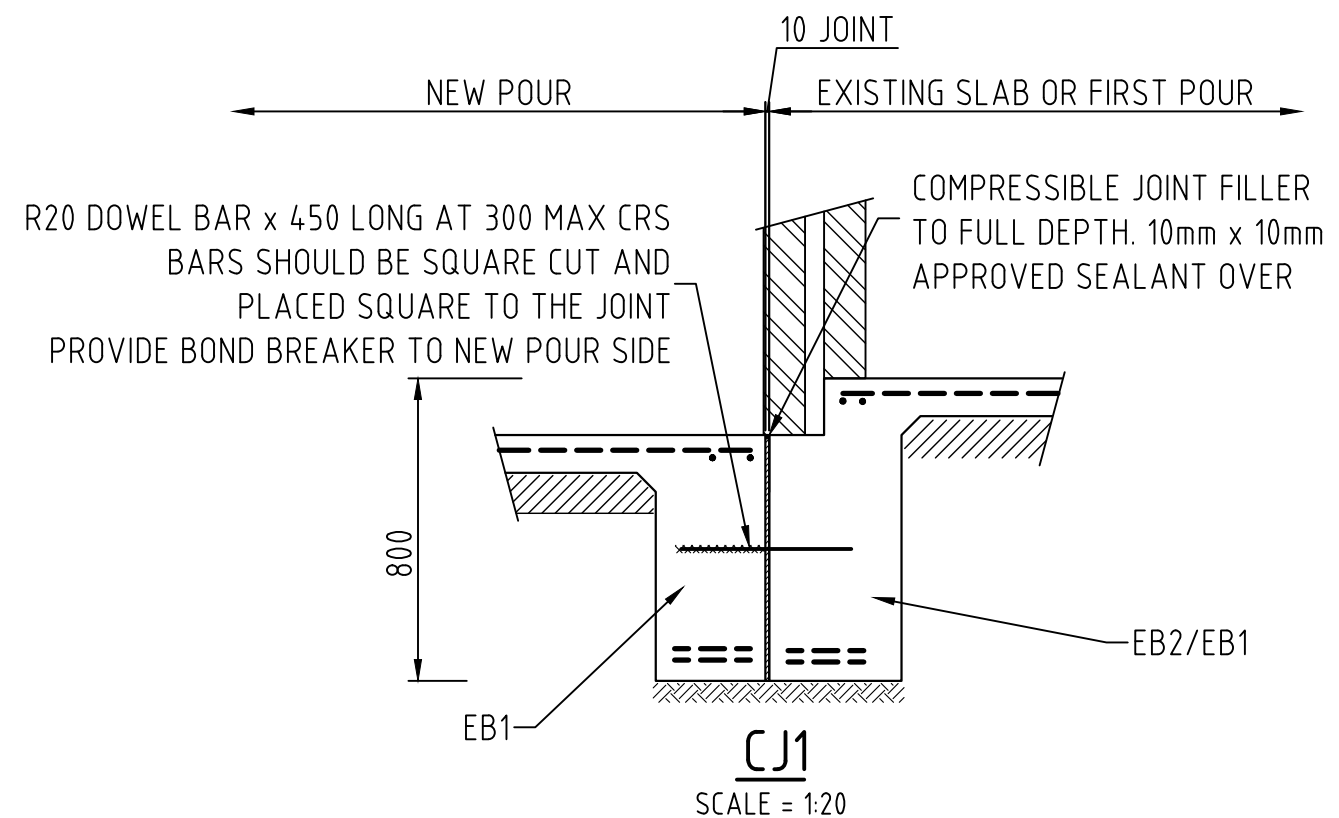

ISSUED FOR APPROVAL

## GENERAL

1. THESE DRAWINGS SHALL BE READ IN CONJUNCTION WITH OTHER WORKING DRAWINGS AND SPECIFICATIONS RELEVANT TO THIS PROJECT. ANY DISCREPANCIES SHALL BE REFERRED TO BARNSON PTY LTD FOR A DECISION PRIOR TO PROCEEDING.
2. ANY NOTES OR DETAILS APPEARING IN THE "PROJECT SPECIFIC" DRAWING SET ARE TO TAKE PRECEDENCE OVER ANY NOTES OR DETAILS APPEARING IN THE "GENERIC" DRAWING SET.
3. DO NOT SCALE FROM THESE DRAWINGS
4. MATERIALS AND WORKMANSHIP SHALL BE IN ACCORDANCE WITH RELEVANT SAA CODES AND LOCAL AUTHORITY REGULATIONS.
5. THE CONTRACTOR SHALL OBTAIN A COPY OF THE SITE GEOTECHNICAL REPORT PRIOR TO CONSTRUCTION, TO FAMILIARISE HIMSELF WITH THE EXPECTED NATURALLY OCCURRING FOUNDATION SOILS.
6. IF SOIL IS ENCOUNTERED DURING CONSTRUCTION THAT IS DIFFERENT TO THAT REFERRED TO IN THE GEOTECHNICAL REPORT, BARNSON PTY LTD SHALL BE CONTACTED IMMEDIATELY PRIOR TO FURTHER WORK TAKING PLACE.
7. DURING CONSTRUCTION, THE STRUCTURE SHALL BE MAINTAINED IN A STABLE CONDITION, AND NO PART SHALL BE OVERSTRESSED.
8. ALL CARE SHOULD BE TAKEN TO ENSURE THAT ADEQUATE SITE DRAINAGE IS PROVIDED TO ENSURE THAT WATER IS DIVERTED AWAY FROM THE BUILDING DURING AND AFTER CONSTRUCTION.
9. ALL FORMWORK SHALL BE IN ACCORDANCE WITH AS3610-1995.
10. PREPOUR INSPECTIONS FOR ALL FOOTINGS AND SLABS SHALL BE CARRIED OUT BY BARNSON PTY LTD OR THE CERTIFYING AUTHORITY. 24 HOURS NOTICE FOR INSPECTIONS IS REQUIRED. NO CONCRETE IS TO BE POURED WITHOUT ATTAINING APPROVAL.
11. FOR SLAB ON GROUND, FINISHED SLAB HEIGHTS ABOVE EXTERNAL FINISHED SURFACES MUST NOT BE LESS THAN:
  - A) 150mm ABOVE FINISHED GROUND LEVEL
  - B) 100mm ABOVE SANDY, WELL DRAINED AREAS
  - C) 50mm ABOVE EXTERNAL SEALED AREAS THAT HAVE A SLOPE OF NOT LESS THAN 50mm OVER THE FIRST 1m FROM THE BUILDING
12. SLABS & FOOTINGS HAVE BEEN DESIGNED BASED ON STANDARD DESIGNS CONTAINED IN SECTION 3 AND ENGINEERING PRINCIPALS CONTAINED IN SECTION 4 OF AS2870-2011, AND ENGINEERING PRINCIPALS FROM AS3600-2009
13. DIMENSIONS GIVEN FOR BEAMS AND STRIP FOOTINGS ARE THE MINIMUM REQUIRED AS PER DESIGN PRINCIPALS NOTED ABOVE. IF THERE ARE SITE SPECIFIC REQUIREMENTS TO WIDEN, OR DEEPEN BEAMS OR STRIP FOOTINGS, IT SHALL BE PERFORMED AS FOLLOWS:
  - A) WHERE BEAMS OR STRIP FOOTINGS ARE WIDER THAN THAT SPECIFIED, AN EXTRA BOTTOM BAR OR EQUIVALENT OF THE SAME BAR SIZE IS REQUIRED FOR EACH 100mm ADDITIONAL WIDTH.
  - B) WHERE BEAMS OR STRIP FOOTINGS ARE DEEPER THAN THAT SPECIFIED, THE BOTTOM REINFORCEMENT SPECIFIED IN AS2870 FOR THE GREATER BEAM OR STRIP FOOTING DEPTH IS TO BE USED.
14. SITE MAINTENANCE IS THE RESPONSIBILITY OF THE OWNER. CSIRO'S - FOUNDATION MAINTENANCE AND FOOTING PERFORMANCE: A HOMEOWNERS GUIDE - BUILDING TECHNOLOGY FILE 18, SHOULD BE REFERRED TO FOR ONGOING SITE MAINTENANCE REQUIREMENTS.

## EXCAVATION

1. TOPSOIL CONTAINING GRASS ROOTS OR VEGETATION SHALL BE REMOVED FROM THE FOUNDATION AREA. IT SHALL THEN BE PROOF ROLLED PRIOR TO FILLING.
2. FOOTING EXCAVATIONS MUST BE FREE OF LOOSE EARTH, TREE ROOTS, MUD OR DEBRIS IMMEDIATELY BEFORE POURING CONCRETE.
3. EXCAVATION FOR FOOTINGS, INCLUDING THICKENINGS FOR SLABS AND PADS MUST BE CLEAN CUT WITH VERTICAL SIDES, WHEREVER POSSIBLE.
4. FOR EXCAVATION REQUIREMENTS ON SLOPING SITES WHERE STEPPED BEAMS OR STEPPED STRIP FOOTINGS ARE TO BE USED, PLEASE REFER GENERIC DRAWING G1002.
5. BARNSON PTY LTD SHOULD BE CONSULTED BEFORE COMMENCING ANY EXCAVATIONS NEAR THE EDGE OF A BUILDING.
7. WHERE PROPOSED FOOTINGS ARE NEAR EXISTING BUILDINGS OR SERVICES, BARNSON PTY LTD MUST BE CONTACTED AS DESIGN CHANGES MAY BE NECESSARY.
8. FOR ALLOWABLE EMBANKMENTS, FILL & CUT TYPE EXCAVATIONS, PLEASE REFER GENERIC DRAWING G1005. TO BE READ IN CONJUNCTION WITH SECTION 6 OF AS2870-2011, AND BCA VOLUME 2, PART 3.1.1 FOR ADDITIONAL INFORMATION.

## BASE PREPARATION - FILL

1. FILLING USED IN THE CONSTRUCTION OF A SLAB, EXCEPT WHERE THE SLAB IS SUSPENDED, SHALL CONSIST OF CONTROLLED FILL AS FOLLOWS:  
CONTROLLED FILL:
  - A) MINIMUM 100mm DEEP MAXIMUM 300mm DEEP UNDER PERIMETER FOOTINGS. IT SHALL BE WELL COMPACTED IN 150mm LAYERS BY A MECHANICAL ROLLER TO A MINIMUM 95% STANDARD COMPACTION FOR A SINGLE STORY DWELLING, AND 98% STANDARD COMPACTION FOR A DOUBLE STORY DWELLING. FILL SHALL BE OF LESS REACTIVITY THAN NATURAL SOIL.
2. FILL WITH A GREATER DEPTH THAN THAT SPECIFIED ABOVE SHALL BE INSTALLED AND CERTIFIED BY A NATA ACCREDITED LABORATORY IN ACCORDANCE WITH AS3798-2007, LEVEL 2.
3. FILL SHALL BE EXTENDED PAST THE EDGE OF THE RESIDENCE AND SHALL BE RETAINED OR BATTERED BY A SLOPE AS SPECIFIED ON DRAWING G1004 OF THE GENERIC DRAWING SET. FOR FILLING REQUIREMENTS IN RELATION TO EDGE BEAMS, PLEASE REFER GENERIC DRAWING G1004.

## BASE PREPARATION - FOUNDATIONS

1. FOUNDATION MATERIAL, WHETHER NATURALLY OCCURRING OR FILL, SHALL HAVE A MINIMUM UNIFORM ALLOWABLE BEARING CAPACITY (Q<sub>a</sub>) OF 100 kPa
2. ALL TESTING TO BE UNDERTAKEN BY A NATA REGISTERED LABORATORY.
3. THE ATTACHED PROJECT SPECIFIC RESIDENTIAL FOOTING DESIGN, HAS BEEN PREPARED BASED ON A SITE CLASSIFICATION CARRIED OUT IN ACCORDANCE WITH AS2870-2011. REFER PROJECT SPECIFIC PLAN FOR METHOD USED.
4. INTERNAL BEAMS/RIBS AND SLAB PANELS SHALL BE FOUNDED ON CONTROLLED OR ROLLED FILL.
5. ALL EDGE BEAMS SHALL BE FOUNDED IN NATURAL SOIL OR CONTROLLED FILL, UNLESS SUPPORTED BY PIERS.

## DAMP-PROOFING MEMBRANE

1. A DAMP-PROOFING MEMBRANE CONSISTING OF A 0.2mm NOMINAL THICKNESS POLYETHYLENE FILM, SHALL BE PLACED UNDER ALL SLABS & BEAMS AND EXTEND TO FINISH AT GROUND LEVEL TO THE SLAB PERIMETER U.N.O.
2. IT SHALL BE HIGH IMPACT RESISTANT IN ACCORD WITH CLAUSES 5.3.3.2 AND 5.3.3.3 OF AS2870-2011, AND BE BRANDED CONTINUOUSLY "AS2870 CONCRETE UNDERLAY, 0.2mm HIGH IMPACT RESISTANCE"
3. IT SHALL BE INSTALLED WITH MIN 200mm LAPS AT ALL JOINTS, AND TAPED OR SEALED WITH A CLOSE FITTING SLEEVE AROUND SERVICE PENETRATIONS.

## REINFORCEMENT

1. ALL REINFORCEMENT SHALL BE IN ACCORDANCE WITH AS/NZS 4671-2001.
2. REINFORCEMENT IS REPRESENTED DIAGRAMMATICALLY, AND IS NOT NECESSARILY SHOWN IN TRUE PROJECTION.
3. REINFORCEMENT DESIGNATIONS AS FOLLOWS:
  - A) N - GRADE 500N HS DEFORMED BAR
  - B) R - GRADE 250R HOT ROLLED BAR
  - C) SL - GRADE 500L SQUARE MESH
  - D) TM - GRADE 500L TRENCH MESH
4. FOR LAPPING JOINTS OF SLAB FABRIC, PLEASE REFER DRAWING G1002 OF THE GENERIC DRAWING SET FOR DETAILS.
5. TRENCH MESH SHALL BE SPLICED WHERE NECESSARY BY A LAP OF 500mm.
6. REINFORCEMENT BARS TO BE LAPPED AS FOLLOWS:
  - A) MESH-2 OUTER BARS OVERLAPPED WITH 2 OUTERBARS+20mm
  - B) N12 BARS = 500mm MIN
  - C) N16 BARS = 700mm MIN
7. ALL REINFORCEMENT IS TO BE ADEQUATELY SUPPORTED IN ITS REQUIRED POSITION. SUPPORT CHAIRS ARE TO BE AT 800mm MAX CENTRES, BOTH DIRECTIONS.
8. SERVICE PENETRATIONS SHALL BE APPROVED BY BARNSON PTY LTD PRIOR TO POURING. ALL SERVICES THAT PENETRATE CONCRETE MEMBERS SHALL BE LAGGED OR SLEEVED. PLEASE REFER GENERIC DRAWING G1003 FOR DETAILS.
9. NO CHASES OR HOLES ARE TO BE MADE IN CONCRETE MEMBERS U.N.O. WITHOUT THE APPROVAL OF BARNSON PTY LTD.
10. PLEASE REFER GENERIC DRAWING G1002 FOR REINFORCEMENT REQUIREMENTS ON SLOPING SITES WHERE STEPPED BEAMS OR STEPPED STRIP FOOTINGS ARE TO BE USED, AND FOR WHERE "L" AND "TEE" INTERSECTIONS OF BEAMS OCCUR..

## CONCRETE

1. ALL WORK AND MATERIALS SHALL BE IN ACCORDANCE WITH AS3600-2009, FORMWORK TO AS3610-1995
2. CONCRETE SHALL NOT BE POURED WHEN THE AIR TEMPERATURE IS GREATER THAN 38 DEGREES, OR LESS THAN 5 DEGREES CELSIUS WITHOUT APPROVAL FROM BARNSON PTY LTD.
3. CONCRETE SHALL BE GRADE N20 (20MPa STRENGTH AT 28 DAYS), HAVE A 20mm NOMINAL AGGREGATE SIZE, AND HAVE A NOMINAL 100mm SLUMP.
4. NO ON SITE WATER IS TO BE ADDED TO THE CONCRETE WITHOUT PERMISSION OF BARNSON PTY LTD.
5. ALL CONCRETE IS TO BE VIBRATED
6. CONCRETE IS TO BE CURED A MIN OF 7 DAYS
7. COVER TO REINFORCEMENT SHALL BE AS FOLLOWS:
  - A) WAFFLE POD SLAB PANELS = 20mm (TOP)
  - B) RAFT SLAB PANELS = 30mm (TOP)
  - C) WAFFLE POD RIBS = 30mm (SIDE)
  - D) WAFFLE AND RAFT SLAB BEAMS = 50mm (BOTTOM & SIDE)
  - E) STRIP & PAD FOOTINGS = 50mm (ALL SIDES)

## MASONRY

1. ALL WORKMANSHIP AND MATERIALS TO BE IN ACCORDANCE WITH AS3700-2001.
2. MASONRY SHALL NOT BE CONSTRUCTED ON CONCRETE ELEMENTS WITHIN 14 DAYS OF CASTING WITHOUT THE APPROVAL OF BARNSON PTY LTD.
3. ARTICULATION OF MASONRY SHALL BE IN ACCORDANCE WITH TECHNICAL NOTE 61 BY THE CEMENT, CONCRETE & AGGREGATES AUSTRALIA. [www.concrete.net.au](http://www.concrete.net.au)





## SITES WITH SALINE AND SULFATE SOILS

1. IN AREAS ADVISED BY THE LOCAL AUTHORITY TO HAVE AGGRESSIVE SOILS THE FOLLOWING MINIMUM REQUIREMENTS ARE TO TAKE PRECEDENCE OVER ANY NOTATION WITHIN THE DRAWING SET:
  - A) THE DAMP-PROOFING MEMBRANE SHALL CONSIST OF A SUITABLE 0.5mm THICK DAMP-PROOFING MATERIAL COMPLYING WITH AS/NZS 2904 AND LAPPED A MINIMUM OF 75mm VERTICALLY OR HORIZONTALLY. DAMP-PROOFING MEMBRANE IS TO BE INSTALLED AND TERMINATED AT FINISHED GROUND OR PAVING LEVEL.
  - B) CONCRETE IS TO BE MINIMUM GRADE N32 (32 MPa STRENGTH AT 28 DAYS AGE). ACTUAL CONCRETE GRADE TO BE UTILISED ON SITE IS TO BE IN ACCORDANCE WITH TABLE 5.3 OF AS2870-2011. TABLE 5.3 IS TO BE READ IN CONJUNCTION WITH TABLES 5.1 AND 5.2 OF AS2870-2011 FOR SITE EXPOSURE CLASS FOR SALINE OR SULFATE SOILS.

## LOADING NOTES

1. ALL LOADS ARE ACCORDING TO AS1170.1-2002
2. LIVE LOADS: 1.5 kPa RESIDENTIAL

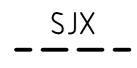
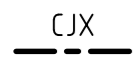
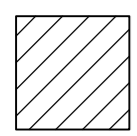
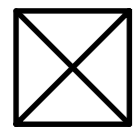
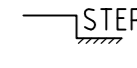
## LEGEND OF DIAGRAMMATIC REFERENCES

-  DENOTES 3-N12 BARS x 2000 LONG OR 3-L11TM x 2000 LONG TIED TO UNDERSIDE OF MESH
-  DENOTES MASONRY ARTICULATION JOINTS  
ARTICULATION OF MASONRY SHALL BE IN ACCORDANCE WITH TECHNICAL NOTE 61 - AUGUST 2008 BY THE CEMENT, CONCRETE & AGGREGATES AUSTRALIA.  
[www.concrete.net.au](http://www.concrete.net.au)
-  BLOCKWORK ARTICULATION JOINT. REFER SPECIFIC DETAIL. TO BE POSITIONED AT 6m MAXIMUM CENTRES.
-  DENOTES TOOL JOINT OR SAW CUT REFER MARK FOR DETAIL
-  DENOTES CONSTRUCTION JOINT - REFER MARK FOR DETAIL
-  DENOTES SLAB RECESS. REFER SPECIFIC DETAILS. REFER ARCHITECTURAL DRAWINGS FOR DEPTH
-  DENOTES SHOWER RECESS. REFER SPECIFIC DETAIL.
-  DENOTES SLAB STEP - REFER MARK FOR DETAIL
-  DENOTES FALLING LEVELS TO FINISHED SURFACE OF SLAB

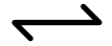
-  DENOTES BEARING PIERS BELOW  
REFER MARK FOR DETAILS
-  DENOTES SPAN DIRECTION OF SUSPENDED SLAB  
PERMANENT FORMWORK - e.g. BONDEK OR CONDEK  
REFER PROJECT SPECIFIC DESIGN FOR SPECIFICATIONS.

## GLOSSARY OF TERMS

- F.S.L. FINISHED SURFACE LEVEL AT COMPLETION OF CONSTRUCTION & LANDSCAPING
- N.S.L. NATURAL SURFACE LEVEL OF SOIL EXPOSED ON SITE AFTER STRIPPING OF TOPSOIL

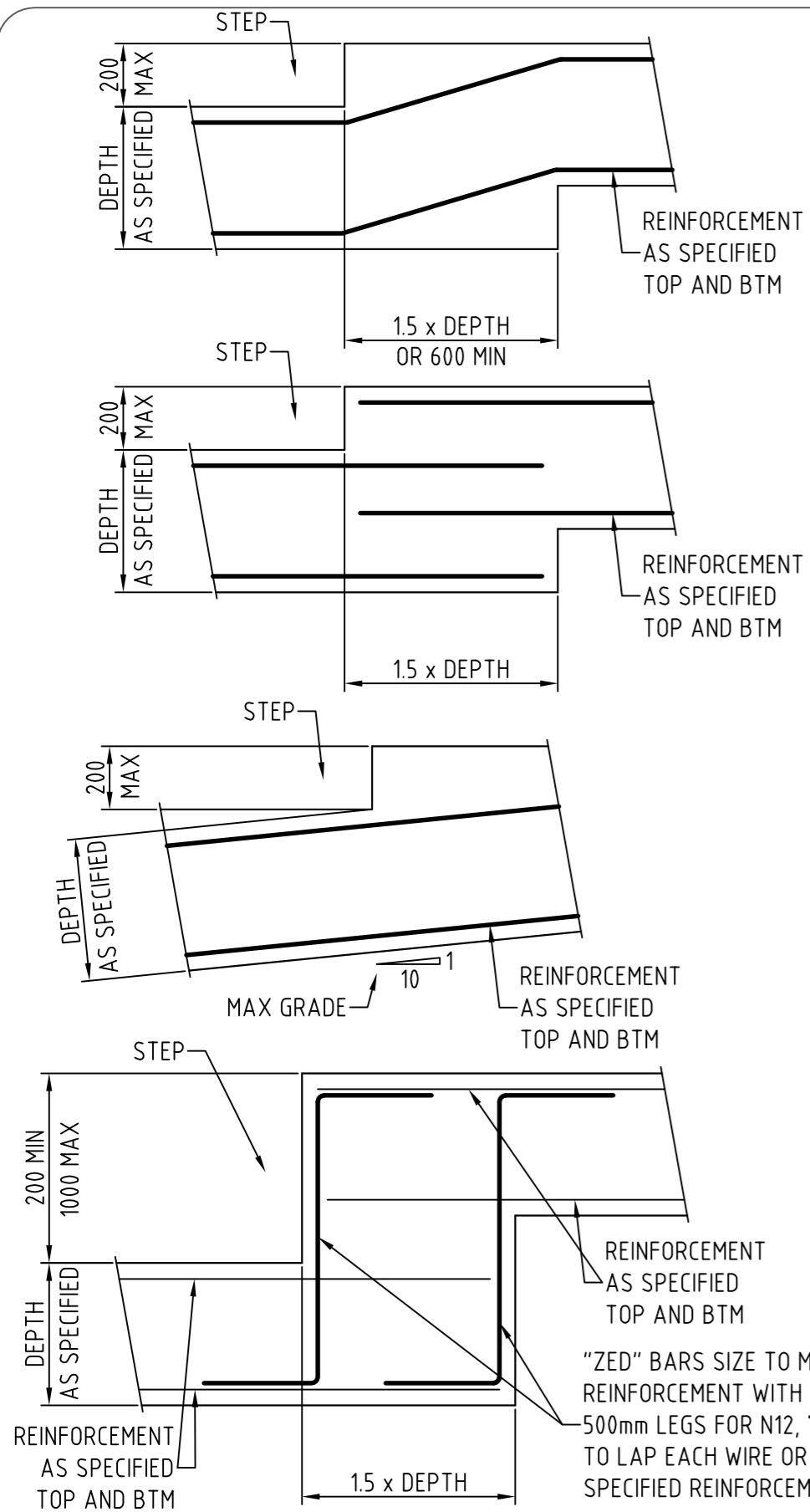

**STRIP FOOTING STEPPING DETAILS**  
SCALE = 1:20

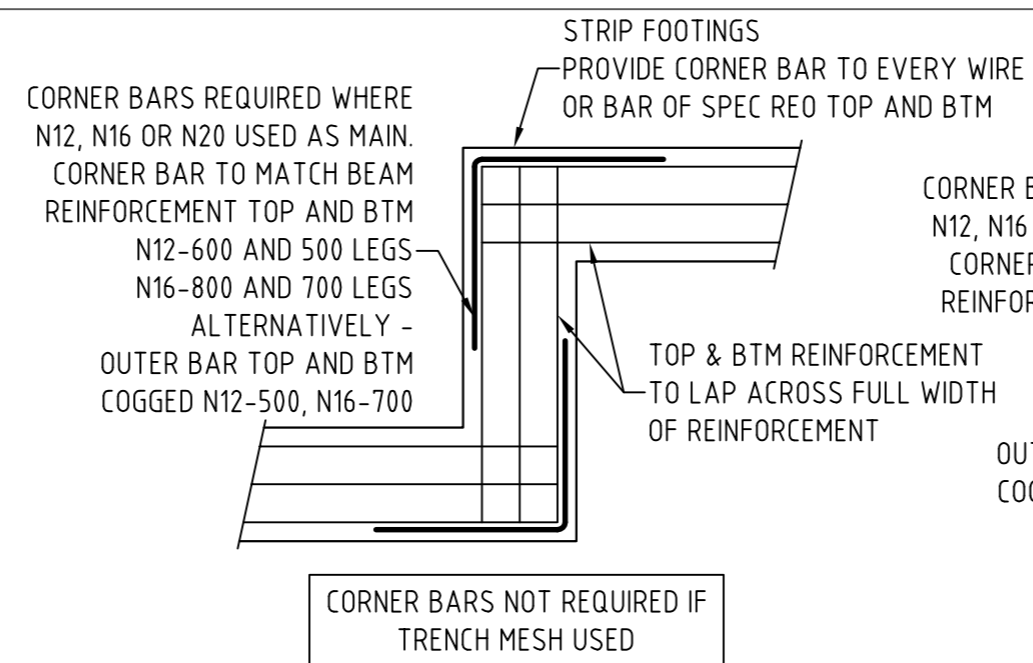

**BEAM "L" INTERSECTION DETAIL**  
SCALE = 1:20

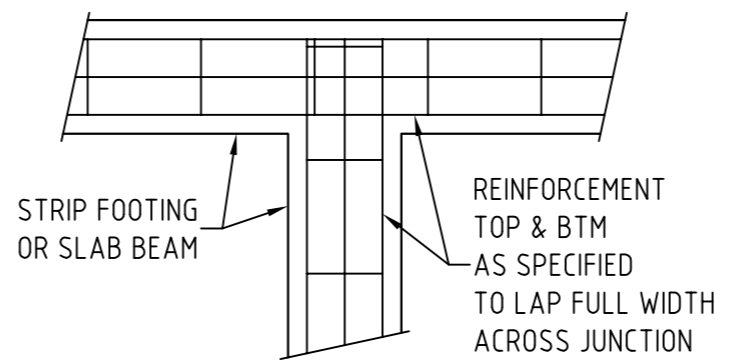

**BEAM "TEE" INTERSECTION DETAIL**  
SCALE = 1:20

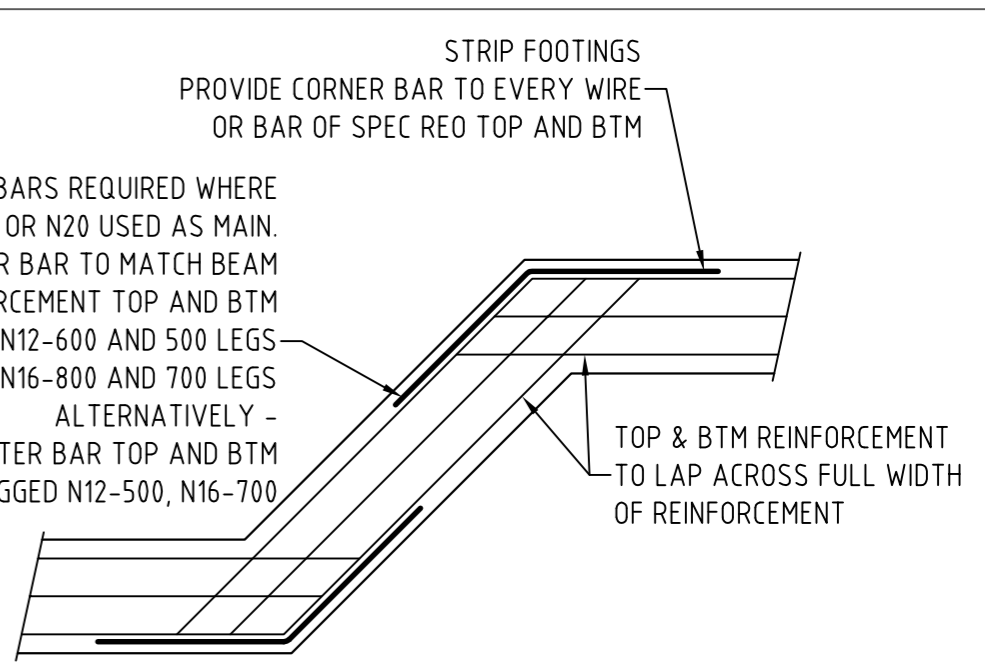

**BEAM BAY WINDOW INTERSECTION DETAIL**  
SCALE = 1:20

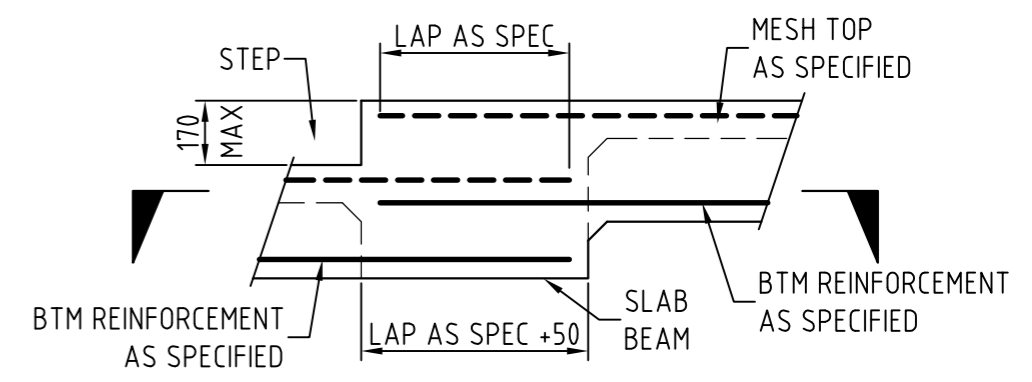
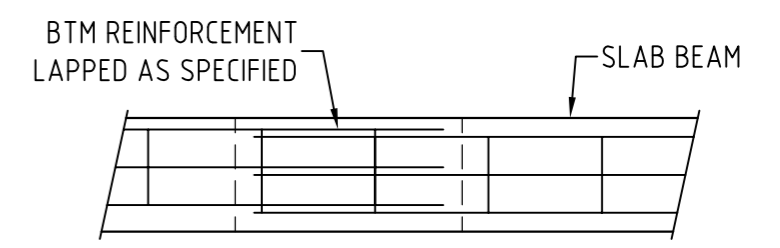

**CONTINUOUS SLAB BEAMS WITH DIFFERENT FOUNDING LEVELS**  
SCALE = 1:20

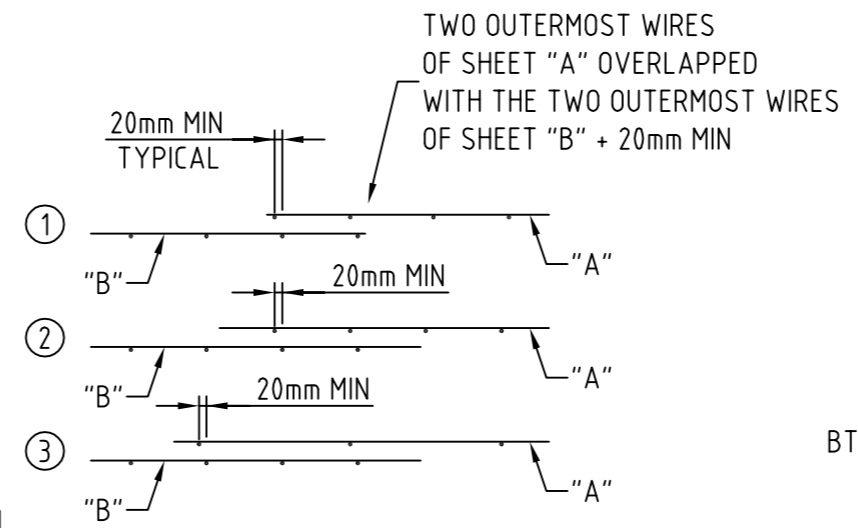

**MESH LAPPING DETAILS**  
SCALE = 1:20

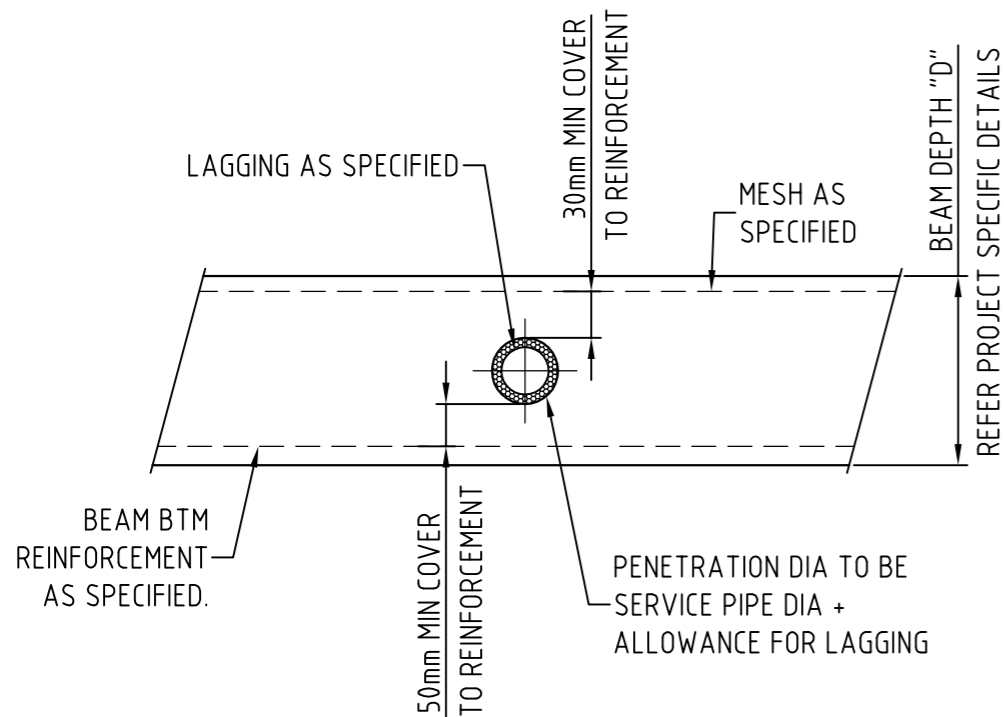

### HORIZONTAL SERVICE PIPE PENETRATION THRU MIDDLE THIRD OF BEAM

SCALE = 1:20

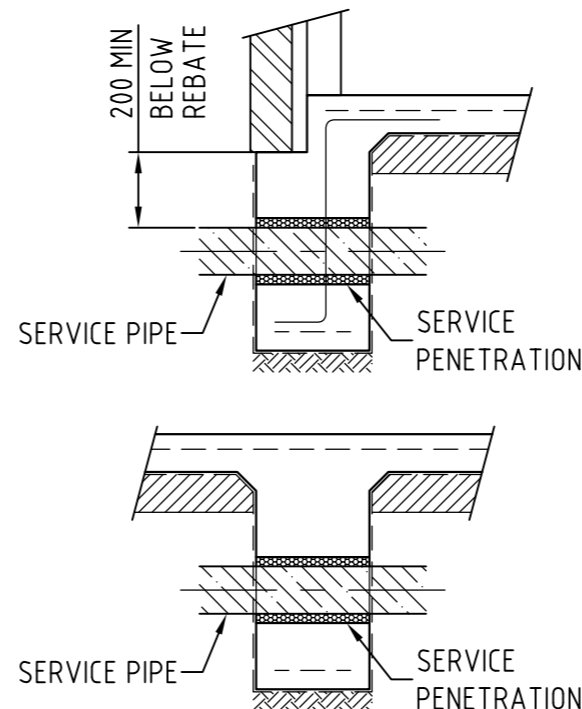

### SERVICE PIPE PENETRATION TYPICAL SECTIONS THRU BEAMS

SCALE = 1:20

### SERVICE PENETRATION NOTES

1. HORIZONTAL SERVICE PENETRATIONS AS DEPICTED ARE DESIGNED TO SUIT PIPES UP TO A MAXIMUM DIAMETER OF ONE THIRD OF THE DESIGN BEAM DEPTH. i.e. D/3.
2. ALL HORIZONTAL PIPE PENETRATIONS THROUGH SLAB BEAMS OR RIBS ARE TO BE WRAPPED IN CLOSED CELL POLYETHYLENE LAGGING TO SUIT THE SITE CLASSIFICATION. NO LAGGING IS REQUIRED FOR SITE CLASSIFICATIONS A AND S. LAGGING SHALL BE A MINIMUM 20mm THICK ON CLASS M, M-D, H1 AND H1-D SITES. LAGGING SHALL BE A MINIMUM 40mm THICK ON CLASS H2, H2-D AND E SITES. OR ALTERNATIVELY PROVIDE SLEEVE WITH SIMILAR ALLOWABLE MOVEMENT.
3. LAGGING NOT REQUIRED FOR VERTICAL SERVICE PANEL PENETRATIONS

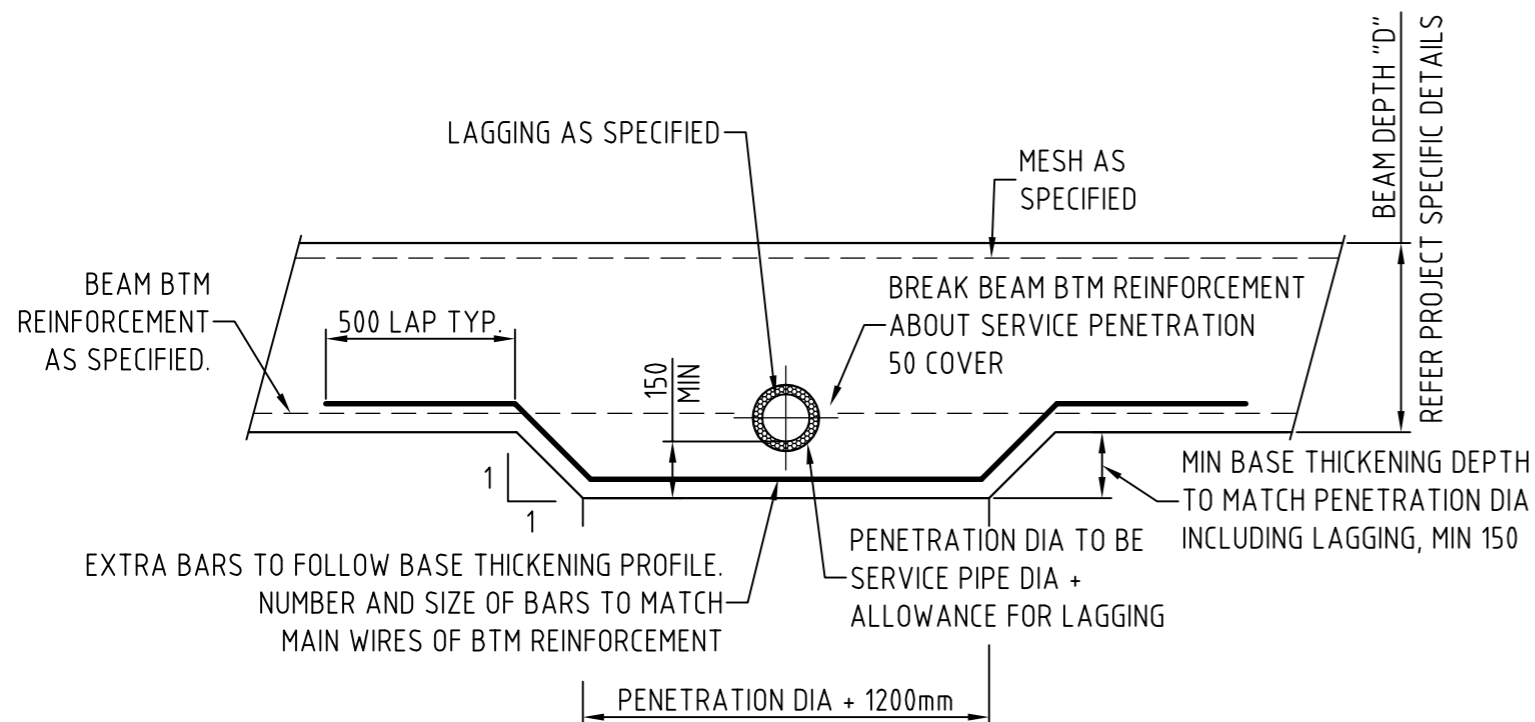

### HORIZONTAL SERVICE PIPE PENETRATION THRU LOWER REGION OF BEAM

SCALE = 1:20

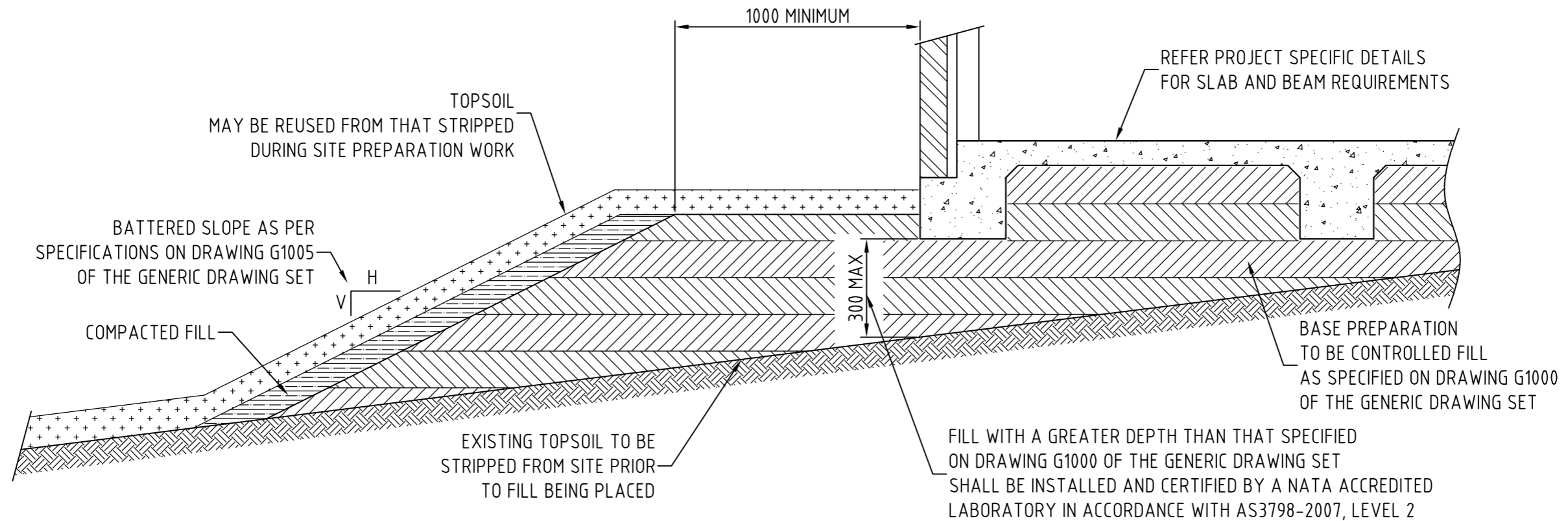

## SLAB EDGE & INTERNAL BEAMS FOUNDED IN CONTROLLED FILL

SCALE = 1:20

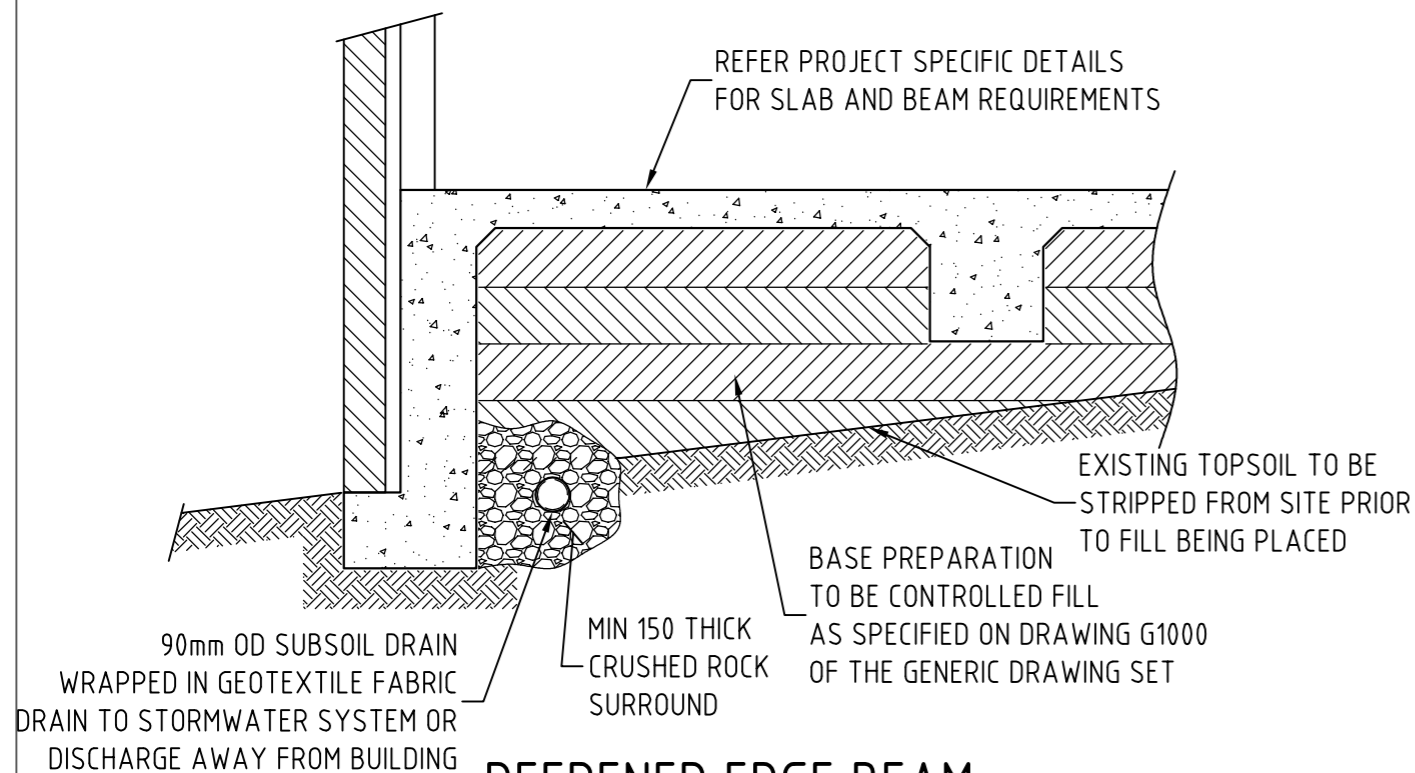

## DEEPEMED EDGE BEAM FOUNDED IN NATURAL SOIL

SCALE = 1:20

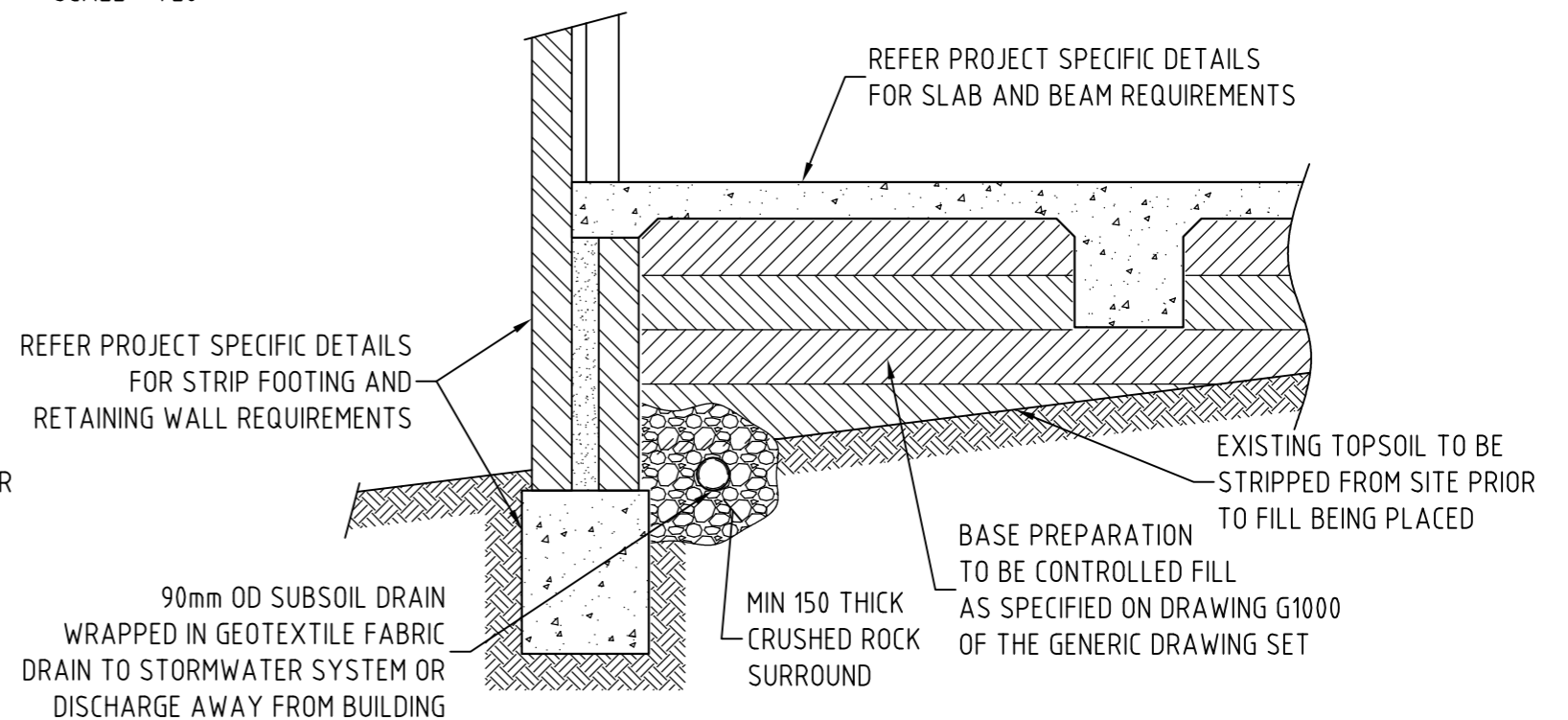

## RETAINING WALL WITH INFILL SLAB FOUNDED IN NATURAL SOIL

SCALE = 1:20



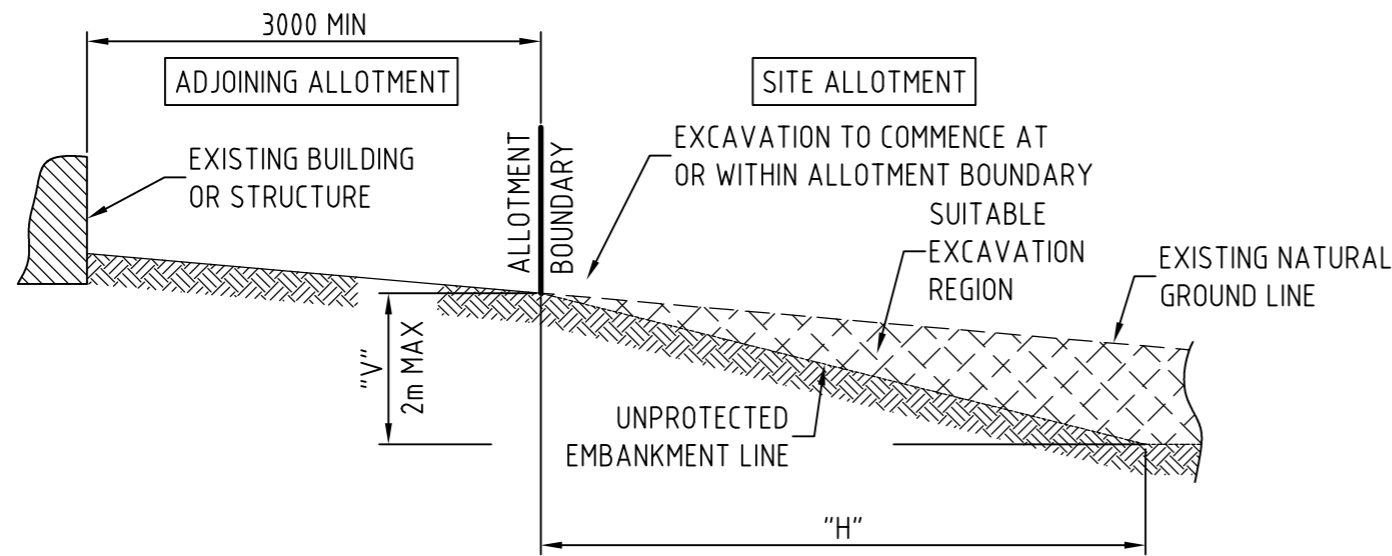

**PERMANENT OR TEMPORARY EXCAVATION WORKS  
ADJACENT ADJOINING ALLOTMENT**

SCALE = 1:50

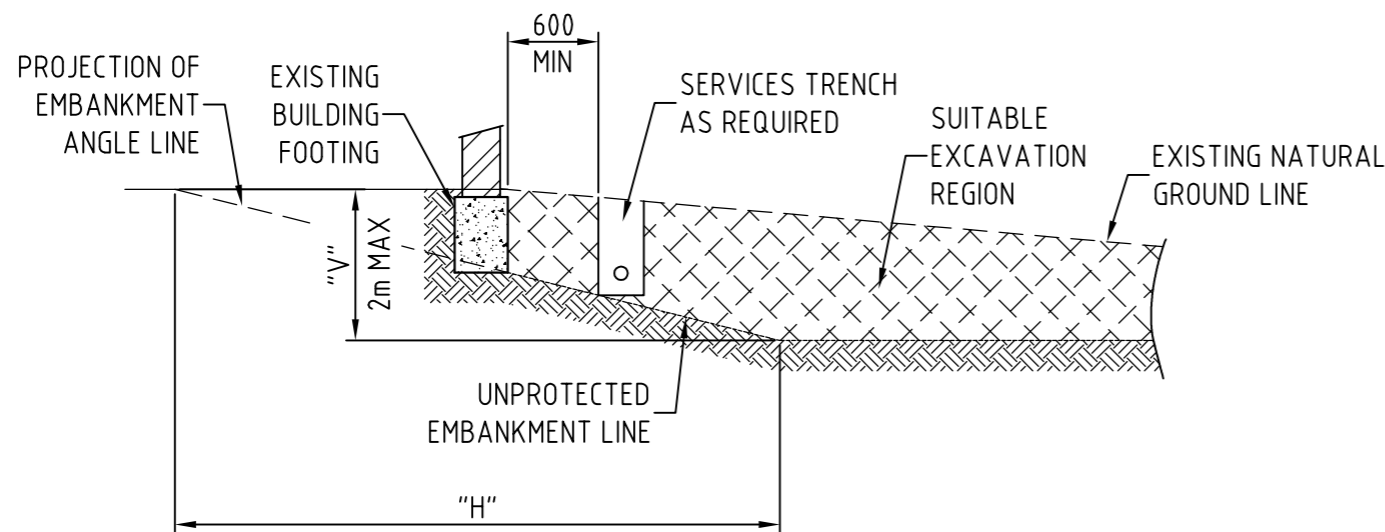

**TEMPORARY EXCAVATION WORKS  
ADJACENT EXISTING BUILDINGS**

SCALE = 1:50

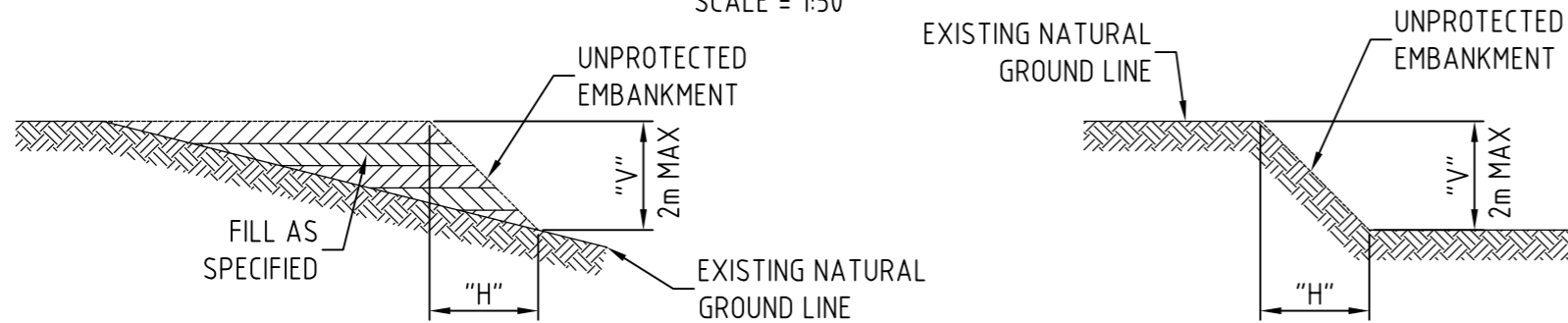

**FILL EMBANKMENT DETAIL**

SCALE = 1:50

**CUT EMBANKMENT DETAIL**

SCALE = 1:50

**EXCAVATION NOTES**

1. ANY PERMANENT VERTICAL OR NEAR VERTICAL EXCAVATION WITHIN 2m OF A BUILDING, AND DEEPER THAN 600mm SHALL BE BATTERED OR RETAINED.
2. THE GRADIENT OF UNPROTECTED EMBANKMENT FOR EXCAVATION INCLUDING BOTH CUT AND FILL SHALL BE ASCERTAINED FROM THE "UNPROTECTED EMBANKMENTS" TABLE.
3. EXCAVATION ADJACENT EXISTING BUILDINGS:
  - A) EXCAVATION WORK FOR FOOTINGS, DRAINAGE TRENCHES OR OTHER SIMILAR WORKS ARE TEMPORARY.
  - B) ELEMENTS REQUIRED SHOULD BE INSTALLED & CONSTRUCTED AS SOON AS PRACTICABLE AFTER EXPOSING THE EXISTING BUILDING FOOTING.
  - C) THE EXISTING FOOTING SHOULD NOT REMAIN EXPOSED AFTER THE COMPLETION OF WORKS.
4. RETAINING WALLS OR OTHER TYPES OF SOIL RETAINING METHODS MUST BE INSTALLED WHERE:
  - A) THE GRADIENT RATIO IS GREATER THAN THAT DESCRIBED IN THE "UNPROTECTED EMBANKMENTS" TABLE.
  - B) SITE SOIL CLASSIFICATION OR DESCRIPTION IS NOT DESCRIBED IN THE "UNPROTECTED EMBANKMENTS" TABLE.
5. FILL SHALL BE PLACED AS FOLLOWS:
  - A) THE GRADIENT RATIO OF FILL DETAILS SHALL BE ASCERTAINED FROM THE "UNPROTECTED EMBANKMENTS" TABLE.
  - B) GENERAL FILL SHALL BE PLACED AND COMPACTED IN LAYERS WITH A VIBRATING PLATE OR SIMILAR COMPACTION EQUIPMENT TO ATTAIN STABILITY.
  - C) WHERE FILL IS TO BE USED TO SUPPORT FOOTINGS OR SLABS, IT SHALL BE CONTROLLED FILL AS DESCRIBED IN GENERIC DRAWING G1000.
6. EMBANKMENTS THAT ARE TO BE LEFT EXPOSED AT THE END OF CONSTRUCTION WORKS MUST BE STABILISED BY VEGETATION OR SIMILAR WORKS TO PREVENT SOIL EROSION.

| UNPROTECTED EMBANKMENTS                                  |  |                             |
|--|--|-----------------------------|
| SITE CLASSIFICATION OR NATURAL SOIL MATERIAL DESCRIPTION | COMPACTED FILL<br>V : H GRADIENT RATIO | CUT<br>V : H GRADIENT RATIO |
| CLASS "A" - STABLE ROCK                                  | 2 : 3                                  | 8 : 1                       |
| CLASS "A" - SAND   | 1 : 2                                  | 1 : 2                       |
| CLASS "S", "M", "M-D" - FIRM CLAY                        | 1 : 2                                  | 1 : 1                       |
| CLASS "S", "M", "M-D" - SOFT CLAY                        | NOT SUITABLE                           | 2 : 3                       |
| CLASS "H1", "H1-D", "H2", "H2-D", "P" - SOFT SOILS       | NOT SUITABLE                           | NOT SUITABLE                |
| CLASS "P" - SILT   | 1 : 4                                  | 1 : 4                       |

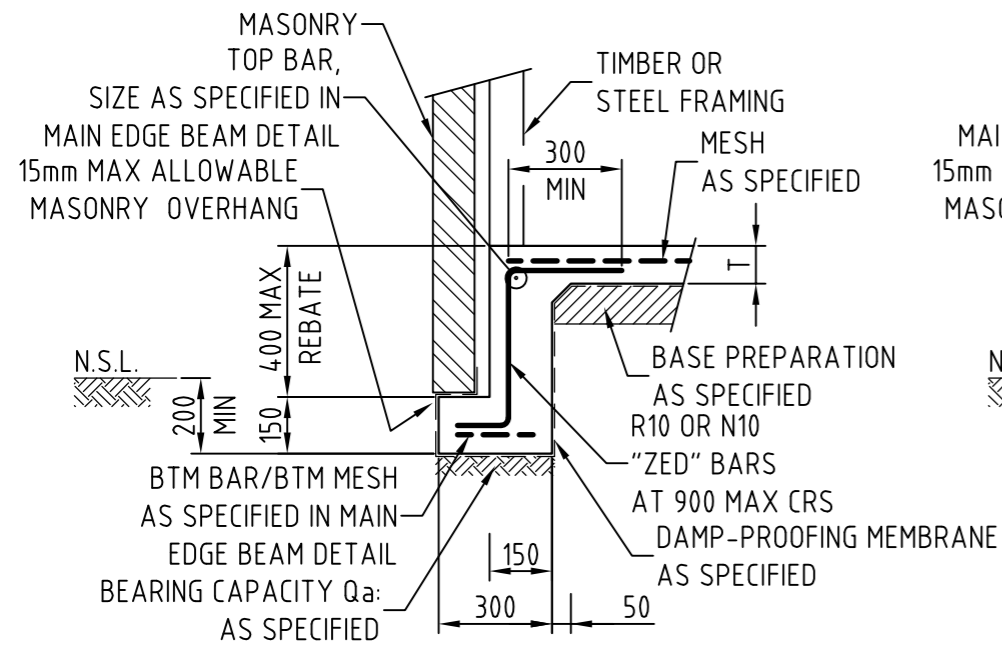

### 400mm MAX REBATE - OPTION 1

SCALE = 1:20

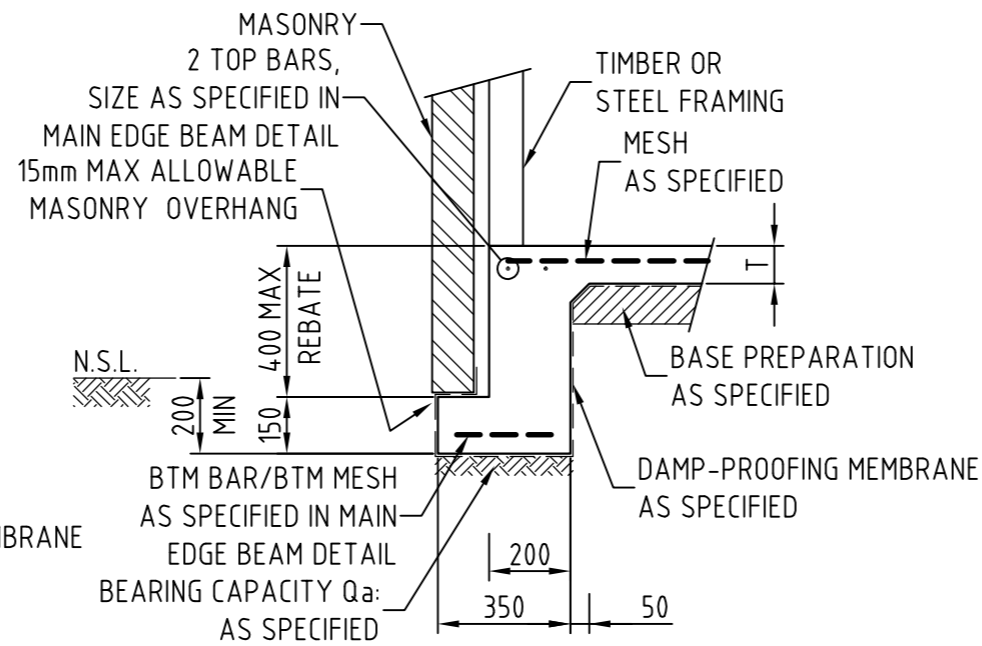

### 400mm MAX REBATE - OPTION 2

SCALE = 1:20

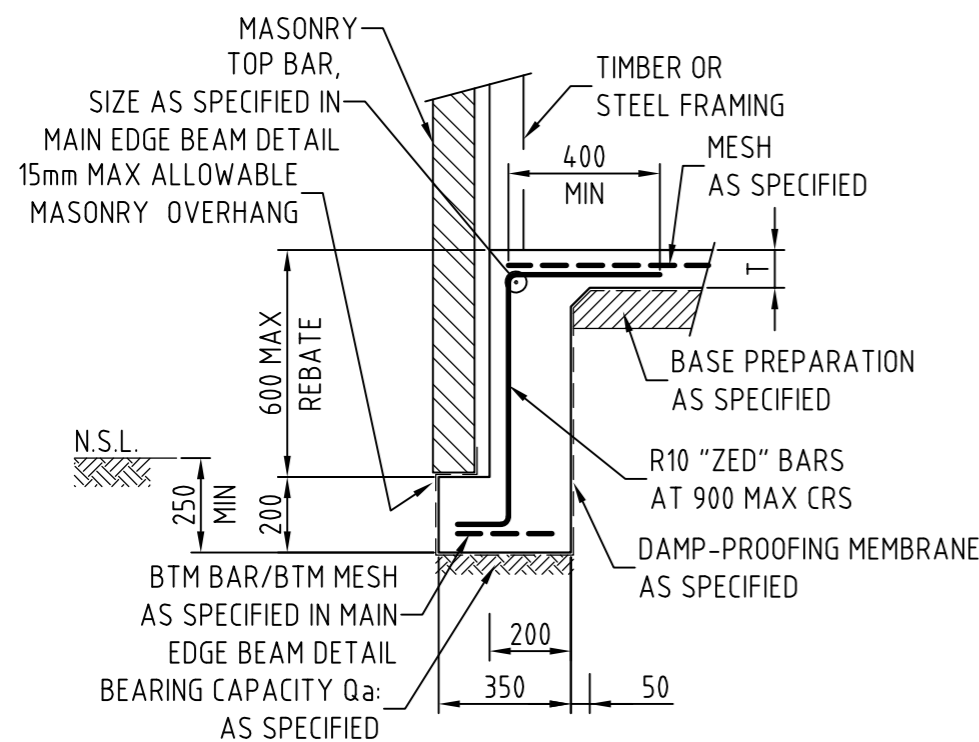

### 600mm MAX REBATE

SCALE = 1:20

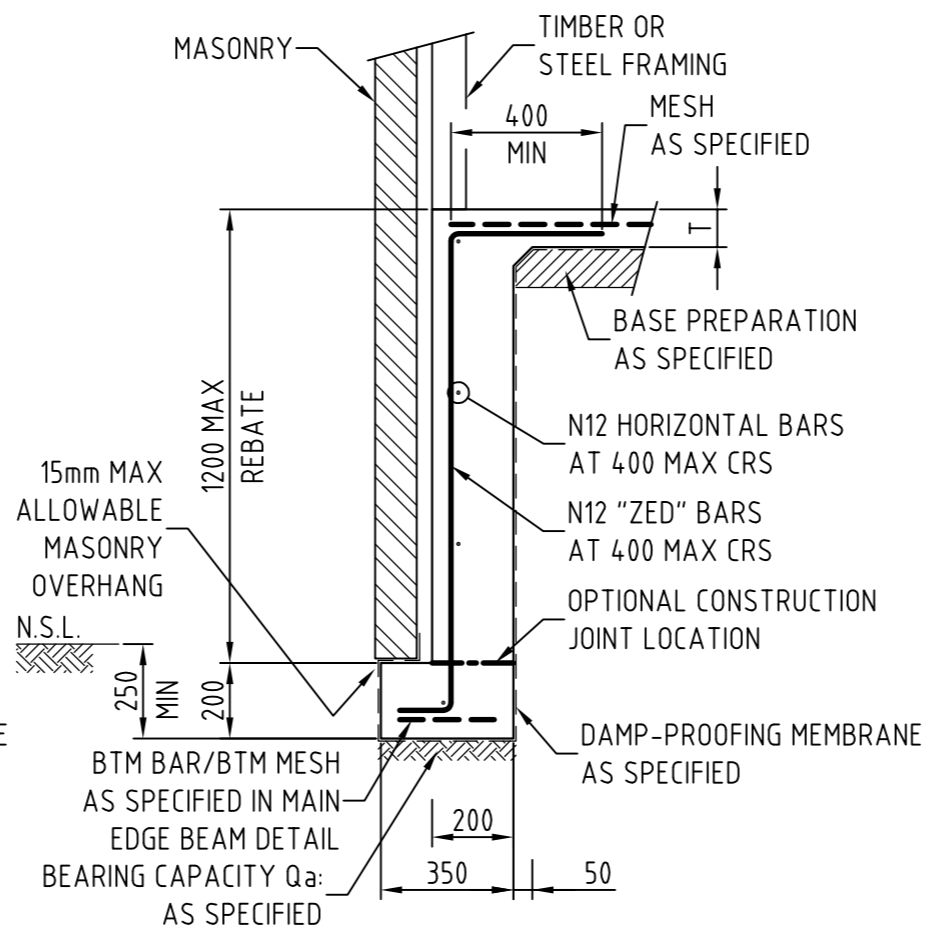

### 1200mm MAX REBATE

SCALE = 1:20

## DEEPEMED EDGE BEAM NOTES

1. DEEPEMED EDGE BEAMS ACCORDING TO THE METHOD OF CONSTRUCTION DEPICTED MAY BE UTILISED IN LIEU OF ANY STANDARD EDGE BEAM DETAILS PROVIDED WITHIN THE PROJECT SPECIFIC DRAWING SET, TO SUIT SITE REQUIREMENTS.
2. FOR PROJECTS REQUIRING DESIGN BEYOND THE PARAMETERS PROVIDED, PLEASE REFER BACK TO BARNSON PTY LTD FOR ADDITIONAL DESIGN SERVICES.

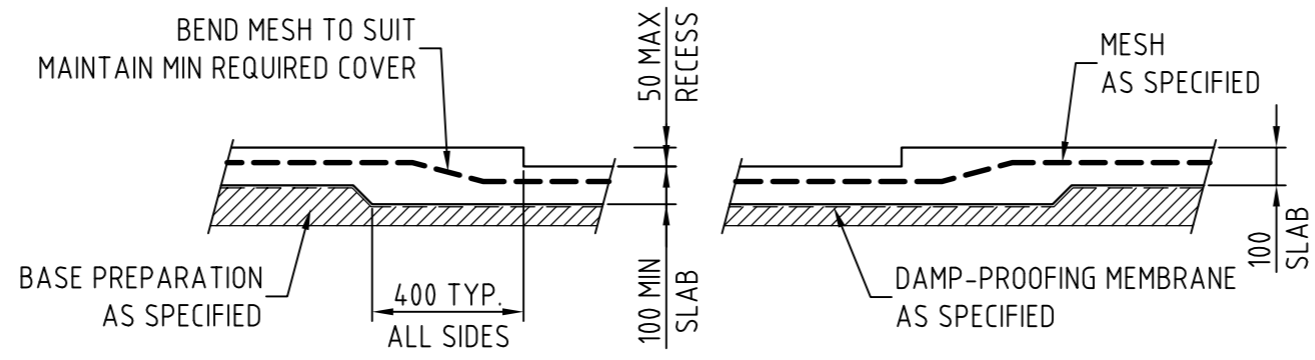

### SHALLOW RECESS

SCALE = 1:20

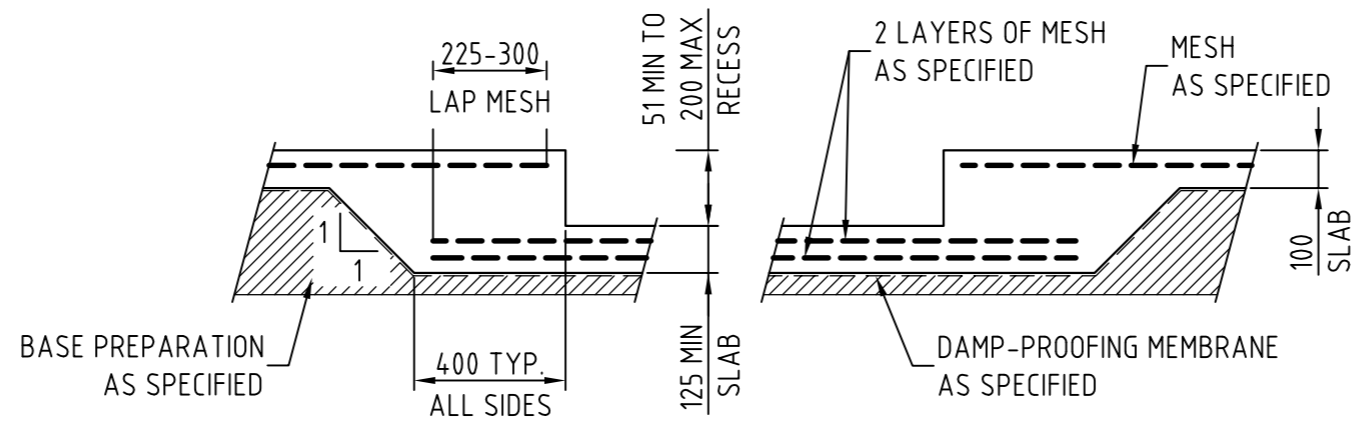

### DEEP RECESS

SCALE = 1:20

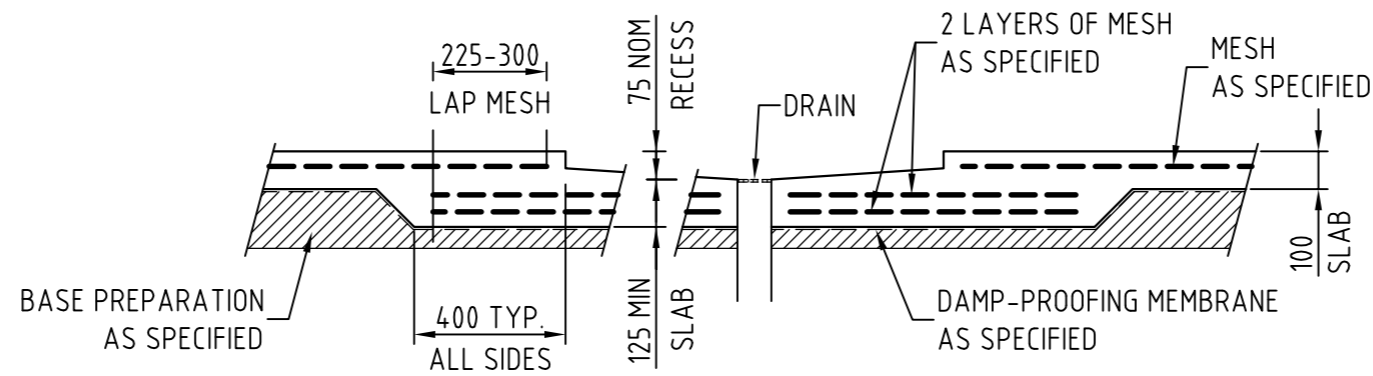

### SHOWER RECESS

SCALE = 1:20